

M3 & M5 PRO SYSTEM

Contents

Legal	4	Installing Hydrophones	24
History	4	List of Marport Hydrophones	25
Copyright	4	Connecting the Hydrophone to the Receiver	27
Disclaimer	4	Adding Temperature Data from the Hydrophones to the System	28
		Understanding Receiver LEDs	29

Introduction and Presentation	5		
Introduction	6		
Safety Guidelines	7		
Description	7		
System Overview	8		
Equipment List	10		
Technical Specifications	12		
Compatibility with Apple Operating Systems	13		

Computer Configuration	15		
Adding a Virtual Keyboard	16		

Installation	19		
Installing the System	20		
System Cabling	22		
Powering the Mx computer	23		
Configuring Mac Mini Network	23		

Maintenance and Troubleshooting	31		
Checking Noise Interference	32		
Troubleshooting	35		
The Mx receiver does not appear on Mosa2 discovery page and the system is not displayed in Scala2	35		
No Internet Access	35		
Antifouling system causes interferences	36		
The Mx computer does not power off immediately	37		
Giving Remote Access to the Computer	37		
Recording Audio Files	37		
Support Contact	39		

Appendix	40		
-----------------	-----------	--	--

Frequency Plan 40

Index a

Legal

History

V1	04/13/23	First release
V2	08/01/24	<ul style="list-style-type: none">• Corrected number of Mx hydrophone junction boxes in the Equipment List (on page 10).• Updated contents in System Overview (on page 8) with Mac mini 2020, that can connect 2 monitors instead of 3 (Mac mini 2018).

Copyright

© 2024 Marport. All Rights reserved.

No part of this document may be reproduced, stored in a retrieval system or transmitted in any form by any means; electronic, mechanical, photocopying or otherwise, without the express written permission from Marport. “Marport”, the Marport logo and Software Defined Sonar are registered trademarks of Marport. All other brands, products and company names mentioned are the trademark and property of its respective owners only. Marport is a division of Airmar Technology Corporation.

Disclaimer

Marport endeavors to ensure that all information in this document is correct and fairly stated, but does not accept liability for any errors or omissions.

Introduction & Presentation

Introduction and Presentation

Introduction

The M3 PRO or M5 PRO system works with an Apple Mac mini, an Mx computer and one Mx receiver. The Mx computer processes the signal and displays the data on a screen connected to the Mac. You can configure the sensors and display data to suit your needs.

The M3 PRO has a full range of capabilities:

- You can listen to 3 hydrophones simultaneously. Only data coming from the hydrophone delivering the best signal are interpreted. As a result, you do not need an hydrophone selection switch, as often used in older types of receivers.
- You can have a simultaneous reception from up to 12 data (depth, pitch, roll...) from standard sensors (such as Door Spread, Catch, Speed sensors).
- You can combine standard sensors with 1 high-definition reception sensor (such as the Trawl Explorer, Trident or Navigator range of sensors).
- You can configure your sensors to have a net monitoring configuration that suits your type of trawl's gear.
- There are 1 NMEA and 2 NTC entries to receive hydrophones' temperature data.

You can upgrade the M3 PRO system to an M5 PRO system to be able to add more standard (up to 100 PRP sensors) and high-definition sensors (up to 10).



Safety Guidelines

 **Important:** To ensure proper and safe use of this equipment, carefully read and follow the instructions in this manual.

Product installation and use

Install and use this product in accordance with this user manual. Incorrect use of the product may cause damage to the components or void the warranty.

Only qualified Marport dealers can do installation and maintenance interventions.

Description

System Overview

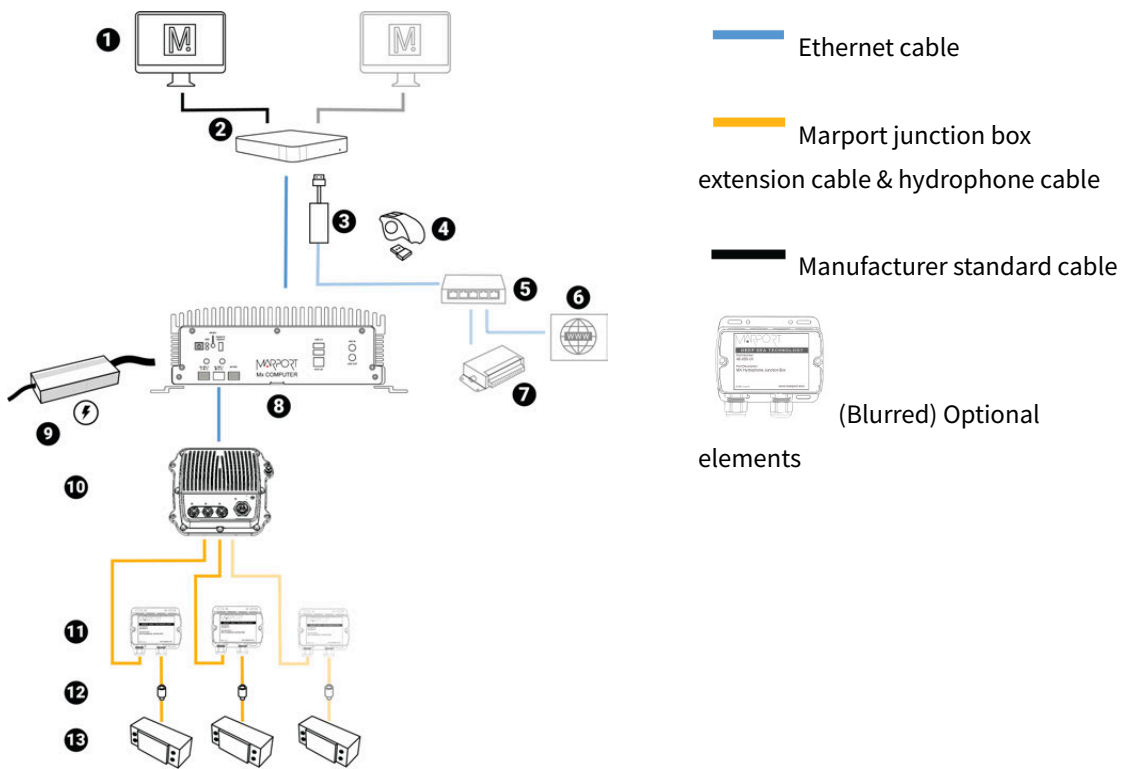

- | | |
|--|---|
| <p>1 Monitors</p> <ul style="list-style-type: none"> • Monitor #1: HDMI • Monitor #2: HDMI/DVI/VGA (with USB-C to adapter cable) <p>2 Mac computer (ref. MAC-0-02)</p> <p>3 USB hub</p> <p>4 Wireless trackball mouse</p> <p>5 Ethernet switch (optional), connected with USB to Ethernet adapter</p> <p>6 Internet (optional)</p> | <p>7 NMEA multiplexer (optional - ShipModul MiniPlex or NPort Device Server)</p> <p>8 Mx computer (ref. SDS-0-01)</p> <p>9 Power supply (recommended power supply: MEAN WELL HEP-150-24 A)</p> <p>10 Mx receiver (ref. M6REC)</p> <p>11 Junction boxes (x2) (ref. 46-055-01)</p> <p>12 Thru-hull penetration (ref. TH-1-XX)</p> <p>13 Hydrophones (ref. NC-1-XX)</p> |
|--|---|

If you need to work with more than two monitors, it is possible to use two Mac minis:

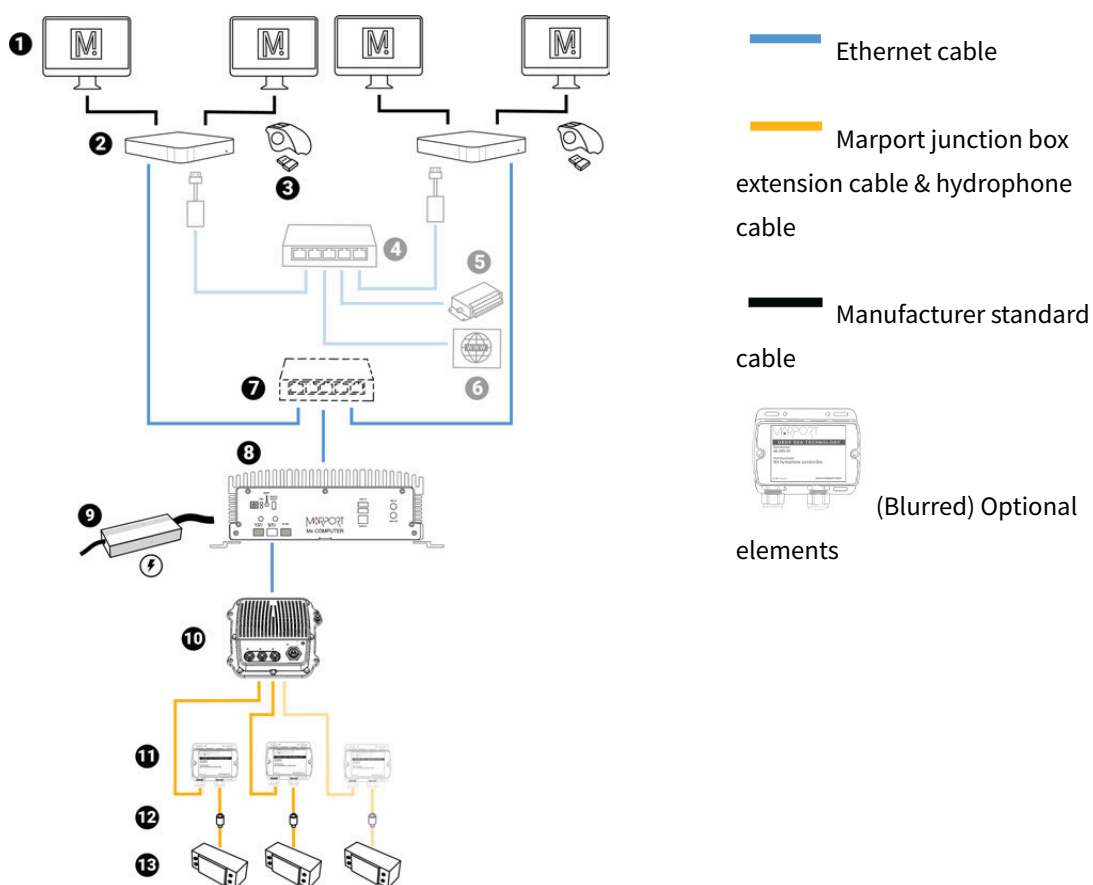

- | | |
|---|---|
| <p>1 Monitors, 2 per mac mini:</p> <ul style="list-style-type: none"> • Monitor #1: HDMI • Monitor #2: HDMI/DVI/VGA (with USB-C to adapter cable) <p>2 Mac computer (ref. MAC-0-02) (x2)</p> <p>3 Wireless trackball mouse (x2)</p> <p>4 Ethernet switch (optional): connected to computers with USB to Ethernet adapter</p> <p>5 NMEA multiplexer (optional): ShipModul MiniPlex or NPort Device Server (necessary to share data between the two computers)</p> <p>6 Internet (optional)</p> | <p>7 Ethernet switch (not provided by Marport)</p> <p>8 Mx computer (ref. SDS-0-01)</p> <p>9 Power supply (recommended power supply: MEAN WELL HEP-150-24 A)</p> <p>10 Mx receiver (ref. M6REC)</p> <p>11 Junction boxes (x2) (ref. 46-055-01)</p> <p>12 Thru-hull penetration (ref. TH-1-XX)</p> <p>13 Hydrophones (ref. NC-1-XX)</p> |
|---|---|



Note: Only one Mac mini computer can share data with Scantrol or with navigation software such as Olex or TimeZero.

Equipment List

Here are the hardware and software you need to install a system with a Mx computer.

Computer

- 1 Mac mini
- 1 wireless trackball mouse
- 1 Mac mini power cord
- 1 Thunderbolt to HDMI/VGA/DVI adapter
- 1 Ethernet cable for connection with Mx computer
- 1 Scala2 software dongle* (not necessary if using license file)

*From Scala2 version 02.12.07, software dongles cannot be used anymore. Use license files instead.

Receiver

- 1 Mx receiver
- 3 Mx hydrophone junction boxes
- 1 CAT5e network cable
- 1 Ethernet connector kit
- 1 Mx hardware kit (mounting screws and ground strap)

Mx computer

- 1 Mx computer fanless Marport V2
- 1 power supply
- Mx computer product numbers:

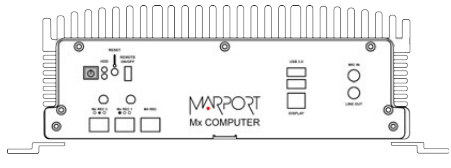
Airmar P/N	Marport P/N	Manufacturer P/N*	Computer front
CMPTR-MX-011222	SDS-0-02	PO boxer-6641	

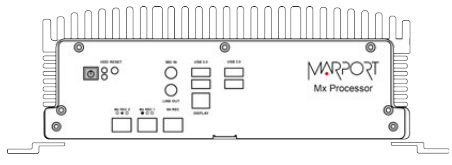
Airmar P/N	Marport P/N	Manufacturer P/N*	Computer front
CMPTR-MX-010419	SDS-0-01	PO boxer-6639M	

*The manufacturer product number is written on a sticker under the computer.

Optional Equipment (not included)

- 1 Uninterruptible Power Supply (UPS) to prevent problems if the mains power fails (recommended). Size: 500VA.
- Additional hydrophone junction boxes
- 1 test hydrophone that you can keep on board and connect to the receiver to do functional tests.
- 1 NMEA converter junction box (ref. NC-2-TEMP) to receive temperature data from hydrophones
- 1 NMEA multiplexer to receive NMEA data and display them in Scala2: ShipModul MiniPlex-3E-N2K if using NMEA2000 and NMEA0183 or Miniplex-3E if using only NMEA0183.

Software

Software Application Name	Definition
Marport validated MacOS	Operating system on computer
Scala2	Marport software application collecting, processing, storing and displaying data received from sensors, sounders and other connected devices.
ScalaReplay2	Marport software application replaying data recorded in Scala2.
Mosa2	Marport software application used to configure sensors. Can be used on desktop or tablet computers.
TeamViewer	To give remote access of your computer to support service

Technical Specifications

Receiver

Frequency range	30-60 kHz
Active bandwidth	24 kHz
Number of Rx/Tx channels	3
Hydrophones	3
Bearing to sensor measurement	Yes
Distance to sensor measurement	Yes
M3 - Number of simultaneous data reception	12
M3 - Number of high resolution sounders (Explorer, Navigator)	1
M5 - Number of simultaneous data reception	50
M5 - Number of high resolution sounders (NBTE, HDTE)	10
Temperature input	2 NTC + 1 NMEA
Network cables	CAT5e, 100 meters max., U/FTP shielding



Important: *Make sure to respect these specifications if installing a new Ethernet network cable.

Mx computer

Dimension (W x H x D)	264.2 mm x 186.2 mm x 96.4 mm (10.4" x 3.8" x 6.1")
Weight	4.5 kg (8.8 lb)
Operating temperature	Ambient with Airflow -20°C ~ 50°C
Storage temperature	-45°C ~ 70°C (-49°F ~ 185°F)
Storage humidity	5~95% @ 40°C, non-condensing
Power supply	9 – 36V with 3-pin terminal block

Compatibility with Apple Operating Systems

This topic lists the supported Apple operating systems for Scala2 and Mosa2.

Scala2

OS name	OS release	Scala 1.x	Scala 2.0.x	Scala 2.2.x	Scala 2.4.x	Scala 2.6.x	Scala 2.10.x	Scala 2.12.x	Scala.2.14.x
Ventura	macOS 13						Yes	Yes	Yes
Monterey	macOS 12.4				Yes	Yes	Yes	Yes	Yes
Big Sur	macOS 11.0				Yes	Yes	Yes	Yes	Yes
Catalina	macOS 10.15		Yes	Yes	Yes	Yes	Yes	Yes	
Mojave	macOS 10.14	Yes	Yes	Yes	Yes	Yes	Yes	Yes	
High Sierra	macOS 10.13	Yes	Yes	Yes	Yes	Yes			
Sierra	macOS 10.12	Yes	Yes	Yes	Yes				
El Capitan	OS X 10.11	Yes	Yes	Yes	Yes				
Yosemite	OS X 10.10	Yes							
Mavericks	OS X 10.9	Yes							

Mosa2

OS name	OS release	Mosa 2.0.x	Mosa 2.3.x	Mosa 2.5.x	Mosa 2.7.x	Mosa 2.9.x	Mosa 2.11.x
Ventura	macOS 13						Yes*

OS name	OS release	Mosa 2.0.x	Mosa 2.3.x	Mosa 2.5.x	Mosa 2.7.x	Mosa 2.9.x	Mosa 2.11.x
Monterey	macOS 12.4				Yes*	Yes*	Yes*
Big Sur	macOS 11.0				Yes	Yes	Yes
Catalina	macOS 10.15	Yes	Yes	Yes	Yes	Yes	Yes
Mojave	macOS 10.14	Yes	Yes	Yes	Yes	Yes	Yes
High Sierra	macOS 10.13	Yes	Yes	Yes	Yes	Yes	Yes
Sierra	macOS 10.12	Yes	Yes	Yes	Yes	Yes	
El Capitan	OS X 10.11	Yes	Yes				
Yosemite	OS X 10.10	Yes	Yes				
Mavericks	OS X 10.9	Yes	Yes				

***Compatibility of Mosa 2.7 and after with Monterey, Ventura, and Sonoma:** A1 sensors cannot connect by short range wireless signal. You must use a Configuration Cable.

Computer Configuration

Computer Configuration

Read this section to learn how to configure the Mac computer.

Adding a Virtual Keyboard

If you do not have a keyboard, you can add a virtual keyboard to the screen and type words using the mouse.

1. From the top left corner of the screen, click **Apple Menu**  > **System Settings**.
2. Click **Keyboard** in the sidebar, then go to **Text Input** and click **Edit**.

3. Turn on **Show Input in menu bar**.

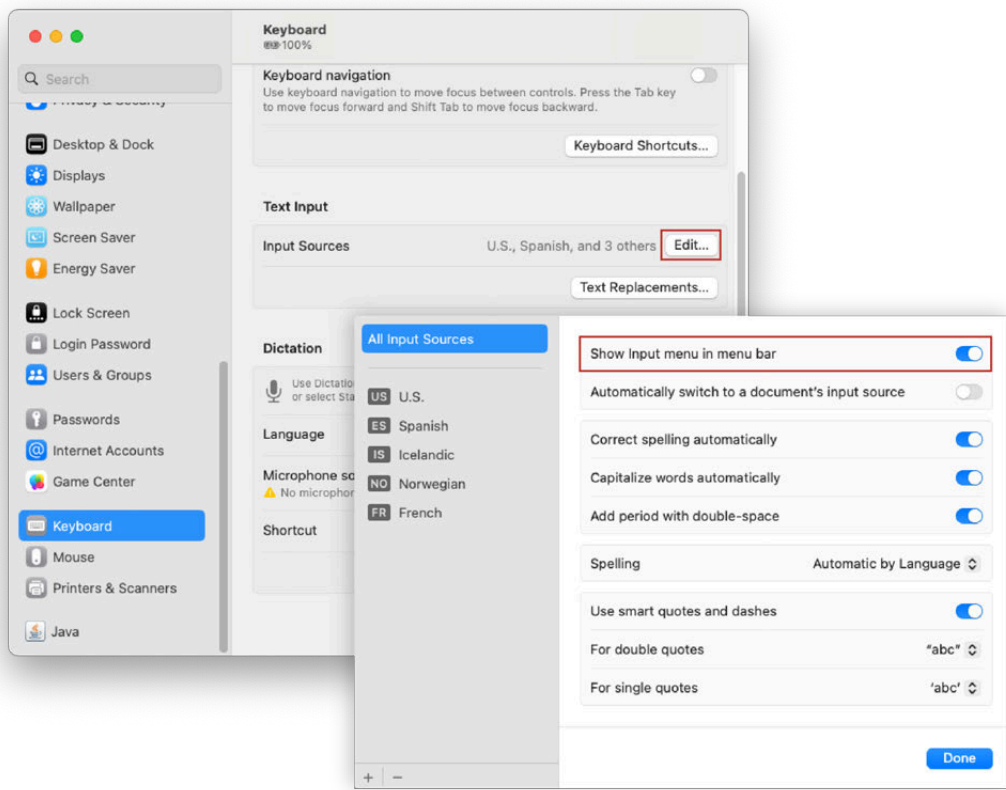

4. From the top right corner of the screen, click the icon corresponding to the keyboard language preferences, then select **Show Keyboard Viewer**.

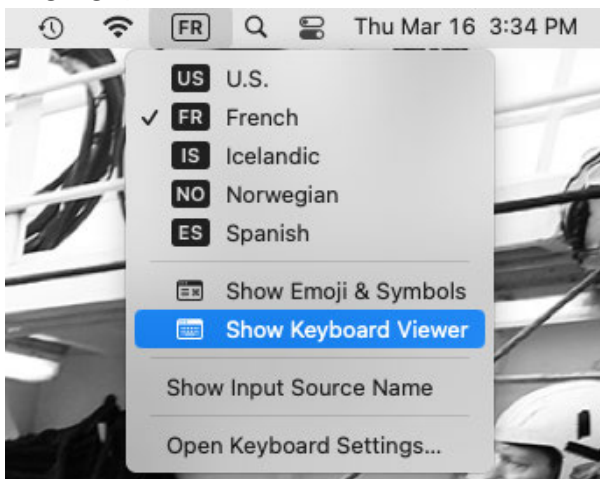

A virtual keyboard is displayed on the screen. You can change its size by dragging its corners.



Installation

Installation

Read this section to learn how to connect and configure the equipment of the M3 PRO system.

Installing the System

Marport technicians or dealers need to connect the different components of the system.



Note: The system is installed by Marport or by a dealer. If there is a problem, you can read these installation steps to check the system installation.

1. Check that you have all the items needed for the installation (See **Equipment List (on page 10)**)
2. Install the hydrophones and their cables, or find the cables from hydrophones that have already been installed.
3. Route the hydrophone cables toward the junction boxes.
4. Put the receiver elevated and/or fixed vertically on a wall in a dry and clean area, as close as possible to the hydrophones. If the receiver is in a closed environment, make sure it is enough ventilated and that the ambient temperature does not exceed 55 °C (131 °F).



Note: Make sure that the cables from the junction box are long enough to reach the receiver.

5. Put the Mac mini mounting bracket elevated and/or fixed vertically on a wall in a dry and ventilated area, without dust, in the wheelhouse.



CAUTION: The receivers are water resistant but not waterproof. The computers are not water resistant. In order to prevent the equipment from being damaged by water:

- Do not install the receiver and computer directly on the floor.
- The cable connectors must not point upwards.

6. Remove the lock screw from the Mac mini mounting bracket, and slide the Mac mini into it. Put the lock screw back and fasten it.
7. Install the monitor(s).
8. Install loudspeakers, if applicable.
9. You can switch on the computer.
10. Configure the networks.

11. Connect the hydrophone cables to the junction boxes and connect the junction boxes to the hydrophone connectors on the receivers Refer to Hydrophone installation manual for detailed guidelines.
12. When adding sensors to the system, refer to the **Frequency Plan (on page 40)** to help you allocating frequencies.

System Cabling

Connect the components of the system according to the following cabling.

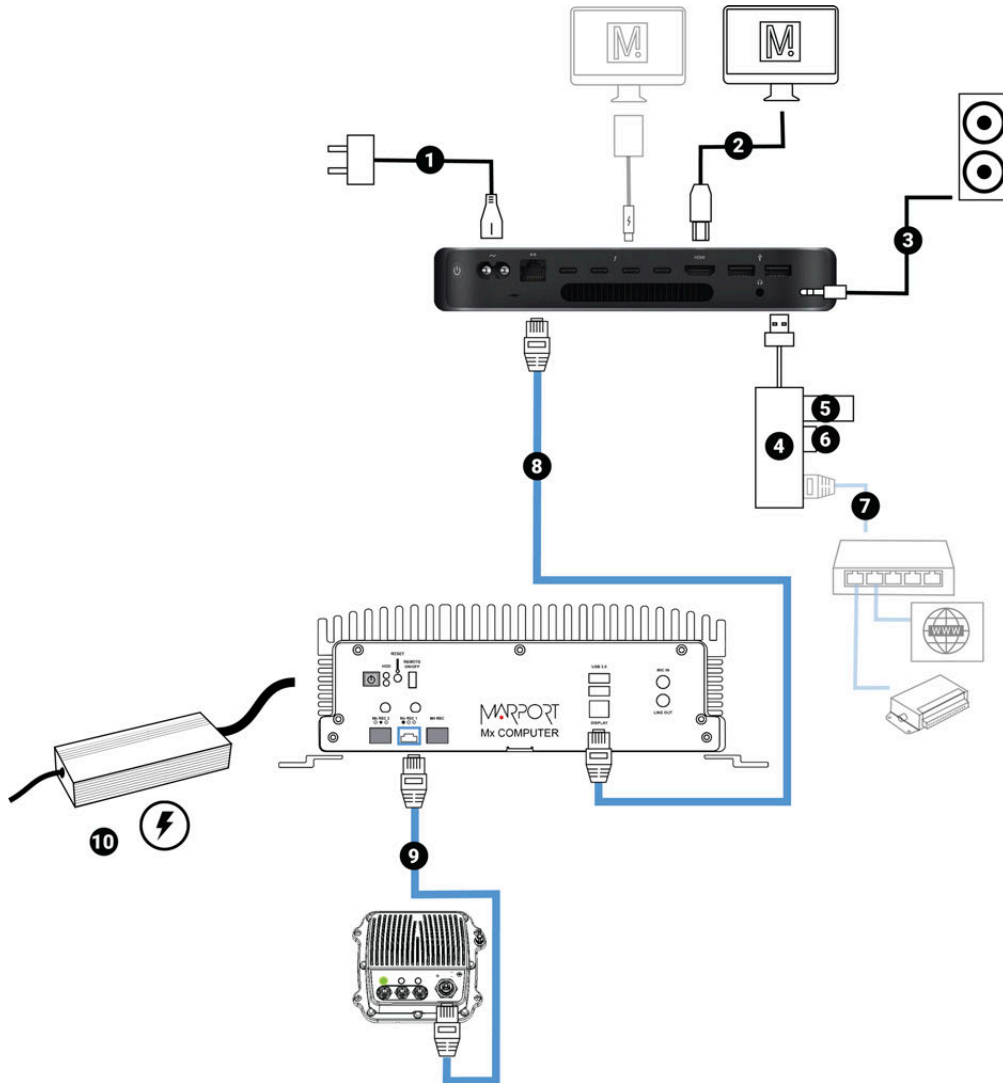

1	Power cable, connected to 100-240V AC power supply*
2	Up to 3 screens (HDMI or thunderbolt cable)
3	Loudspeakers (if applicable)
4	USB hub
5	Scala2 software dongle (not necessary if using a license file)
6	USB trackball transmitter of the wireless trackball mouse

7	Connection to an Ethernet switch if you need to be connected to both an Internet connection and external devices.
8	Connection to Mx computer using CAT5e network cable
9	Connection to Mx receiver using CAT5e network cable
10	Power supply

* We recommend to use an Uninterruptible Power Supply (UPS) to prevent problems if the mains power fails.

Powering the Mx computer

1. Connect the power cable to the Mx computer.

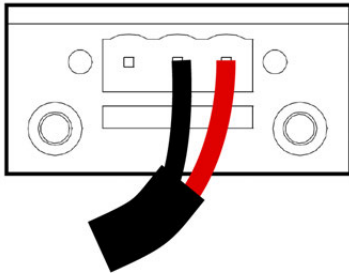

2. Connect MEAN WELL power supply to a power socket.

3. Press  on the Mx computer to switch it on.

Configuring Mac Mini Network

By default, the IP address of the Mx computer is 192.168.1.170. You need to change the IP address of the Ethernet port connected to the Mx computer so the Mac computer can communicate with it.

1. From the top left corner of the screen, click **Apple Menu**  > **System Settings**, then click **Network** in the sidebar.
2. If using an internet router, it must be connected to the port named **USB 10/100/1000 LAN**. If you connect to the internet via a WiFi network, make sure it is at the top of the list

of networks. If not, click the menu on the bottom right corner of the window and select **Set Service Order**.

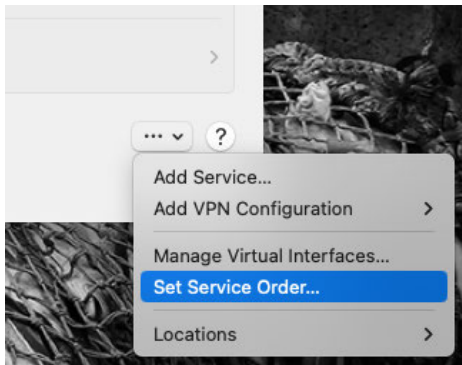

3. In the network list, click **Ethernet**, then **Details**:
 - a. In **Configure IPv4** menu select **Manually**.
 - b. In **IP Address**, enter 192.168.1.100.
 - c. In **Router**, enter 192.168.1.1.

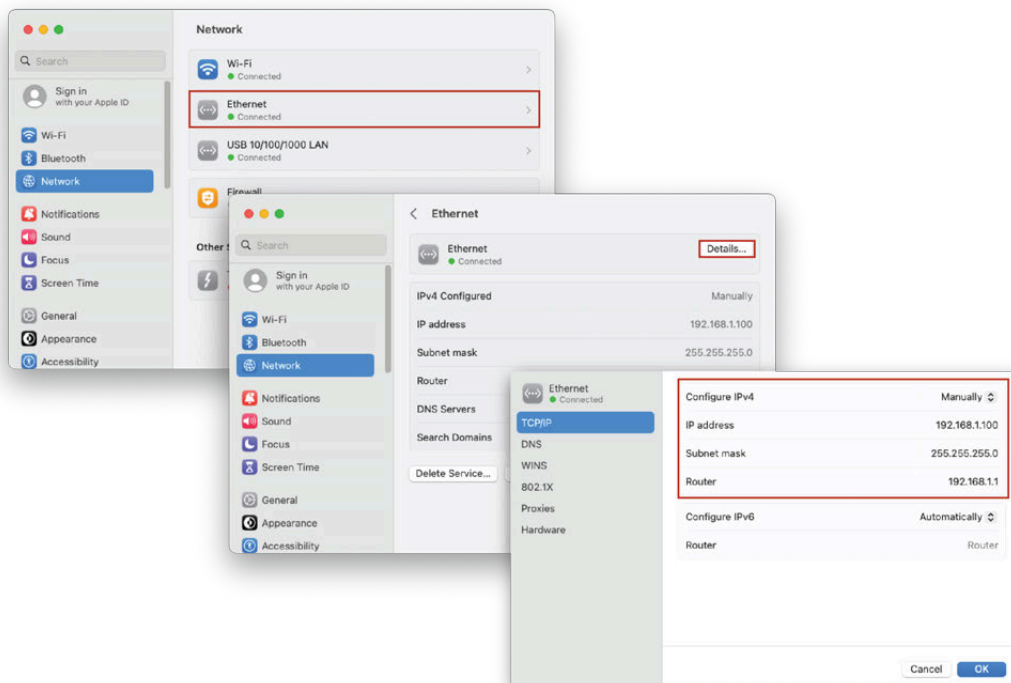

4. Click **OK**.

Installing Hydrophones

You need to connect hydrophones to the system.

List of Marport Hydrophones

These are technical specifications for hydrophones currently sold by Marport. For information about obsolete hydrophones, please contact Marport support.

Product reference	Name	Use case	Bandwidth (3 dB)	Typical current consumption	Cable ¹
NC-1-05	Passive wideband hydrophone (no preamplifier)	<ul style="list-style-type: none"> • Vessel with very low level of noise (below -110 dBV) • Sensors close to the vessel (approx. 300 m) • For positioning systems with Slant Range/pinger (one passive hydrophone is necessary for transmission) 	33-60 KHz	0.0 mA	Blue
NC-1-05 + NC-2-02	Passive hydrophone + Wideband preamplifier box	<ul style="list-style-type: none"> • Vessel with normal level of noise (below -100 dBV) • Large number of sensors² • Use at great depths (> 500 m) • Gain configurable (Low or High) • Filters configurable (38 and/or 50kHz) • Low noise environment between passive hydrophone and wideband preamplifier box 	33-60 KHz	25-29 mA	Blue

Product reference	Name	Use case	Bandwidth (3 dB)	Typical current consumption	Cable¹
NC-1-07	Active hydrophone (integrated preamplifier)	<ul style="list-style-type: none"> • Vessel with normal level of noise (below -100 dBV) • Limited number of sensors² • No filtering options. • Not used for positioning system 	41-44 KHz	4-6 mA	Green
NC-1-06	Active wideband hydrophone (integrated preamplifier)	<ul style="list-style-type: none"> • Vessel with normal level of noise (below -100 dBV) • Large number of sensors² • Use at great depths (> 500 m) • Gain configurable (Low or High) • Filters configurable (38 and/or 50kHz) 	30-60 KHz	25-29 mA	Yellow
NC-1-08	Active wideband hydrophone (integrated preamplifier)	<ul style="list-style-type: none"> • Vessel with normal level of noise (below -100 dBV) • Large number of sensors² • Use at great depths (> 500 m) • Gain configurable (Low or High) • Filters configurable (38 and/or 50kHz) 	30-60 KHz	18-22 mA / 18-24 mA ⁴	Yellow

Product reference	Name	Use case	Bandwidth (3 dB)	Typical current consumption	Cable ¹
NC-1-09 ³	Active hydrophone (integrated preamplifier)	<ul style="list-style-type: none"> • For use on a paravane only • Vessel with normal level of noise (below -100 dBV) • Limited number of sensors² • No filtering options • Not used for positioning system 	41-44 KHz	4-6 mA	Blue, heavy-duty

¹Note that cables are colored according to the type of hydrophone: blue for passive, green for active narrowband and yellow for active wideband.

²Standard active hydrophones have an available bandwidth of 6kHz. So, if: $(PRP_number * 100) + (NBTE_number * 800) < 6000$ you have enough place. If: $(PRP_number * 100) + (NBTE_number * 800) > 6000$ then you need a wideband hydrophone.

³Add as NC-1-07 in the receiver configuration page.

⁴Hydrophones with the serial number **A000G85P and after** have a higher power supply current limit (24 mA) than the earlier models. In order to be compatible, the Mx receiver version must be updated to 08.05.14 version.

Connecting the Hydrophone to the Receiver

You need to connect the hydrophone to the receiver to be able to display sensor data received by the hydrophones.

Connect the extension cable of the junction box to a hydrophone input on the receiver:

- Connect to the NTC hydrophone input H1 or H2 to be able to receive water temperature from Marport hydrophones.

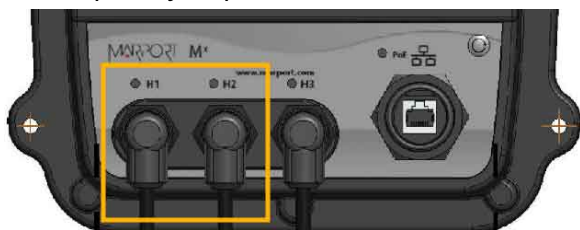

-  **Note:** H3 hydrophone input allows to receive water temperature from an NMEA connection (Scanmar hydrophone or NMEA converter junction box). If you connect a Marport hydrophone to H3 without NMEA converter, you will not have temperature data from the hydrophone.

Adding Temperature Data from the Hydrophones to the System

You can add the hydrophone to the receiver as a sensor in order to display in Scala2 the temperature of the water surface.

-  **Important:** In order to receive temperature data, make sure the hydrophone is connected to an NTC input on the receivers or is connected using an NMEA converter junction box. See **Connecting the Hydrophone to the Receiver (on page 27)** for guidelines.

1. From Scala2, click **Menu**  > **Expert Mode** and enter the password `copernic`.
2. Right-click the IP address of the receiver at the bottom of the page, then click **Configure Receiver**.
3. From the left side of the page, click **Sensors**.

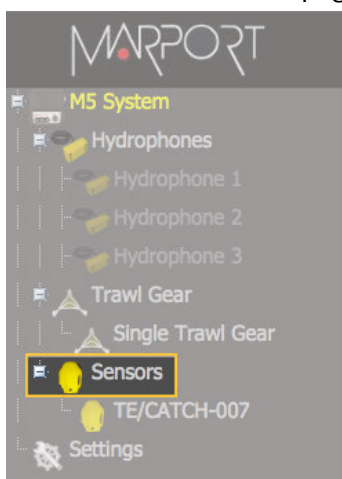

4. Under **Add Sensor Product**:

- a. Select **Hydrophone** in the **Product Category** menu.
- b. In the **Product Name** menu, select **NMEA temperature** if using an NMEA converter junction box, or **NTC temperature** if the hydrophone is connected to an NTC input.
- c. In **Hydrophone Location**, select the number of the receiver's port on which the hydrophone is connected.

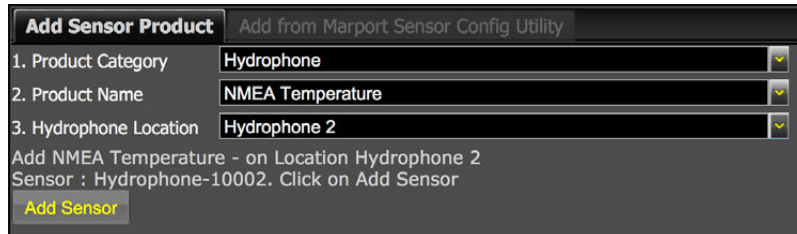

- d. Click **Add Sensor**.

The water temperature is displayed in Scala2, in the control panels, under **Mx**.

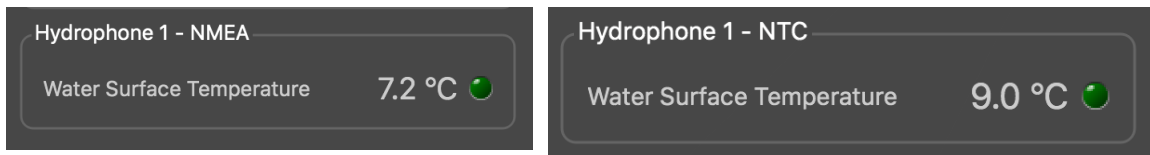

Understanding Receiver LEDs

LEDs on the receiver are useful to know if the receiver is connected to the computer and what types of hydrophones are connected to the receiver.

Boot sequence

When the receiver restarts, the hydrophone and PoE LEDs light up according to a specific sequence. At the end of the sequence:

- LEDs are off if no hydrophone is configured.
- LEDs are red or blue if hydrophones are configured.

If one or several LEDs stay green after the boot sequence, there is a problem with the receiver. Contact your local support service.

PoE LED

You can refer to the PoE LED color to know if the receiver is correctly connected to the computer.

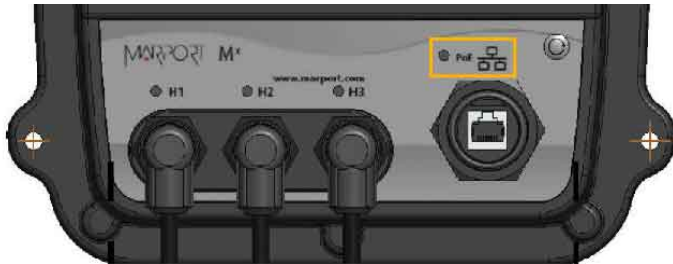

- Blinking green: the receiver is connected to a power source and to the computer.
- Blinking blue: the receiver is connected to a power source but it is disconnected from the computer. Check that the computer is connected to the Mx computer.
- Blinking red: Ethernet is resetting.

Hydrophone LEDs

The LEDs on the hydrophone inputs identify the type of hydrophone that is connected to the receiver.

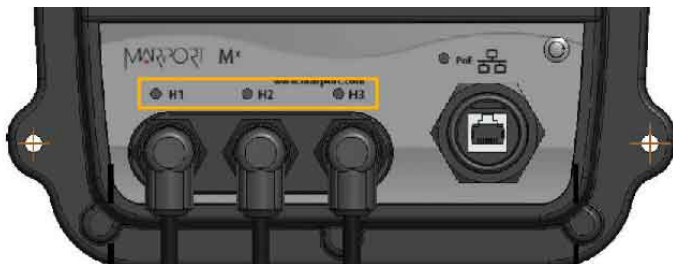

- Blue: passive hydrophone
- Red: active hydrophone
- No light: no configured hydrophone

Maintenance & Troubleshooting

Maintenance and Troubleshooting

Read this section for troubleshooting and maintenance information.

- ! **Important:** Only an approved Marport dealer can access the internal unit. Warranty will become void if anyone other than an approved dealer tries to do internal maintenance duties on the product.

Checking Noise Interference

Use the spectrum analyzer to check the noise level of the hydrophones and check for interference.

1. Click Add + to create a new page on which you will add the spectrum analyzer(s).
2. Right-click the IP address of the receiver in the status bar and click **Start Spectrum**.

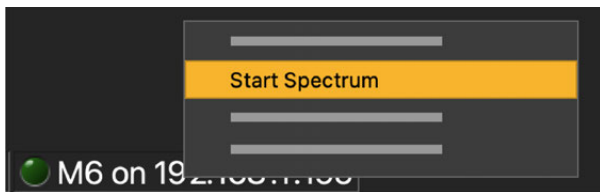

3. Open the control panels and go to the **Mx** panel.
4. Go to **Hydrophone** data, then drag and drop **Spectrum** data to a page. These data appear only when the spectrum has been started.



5. The spectrum analyzer is displayed. You can display up to 6 spectrum analyzers at the same time. Below is an example of a page with 2 spectrum analyzers.

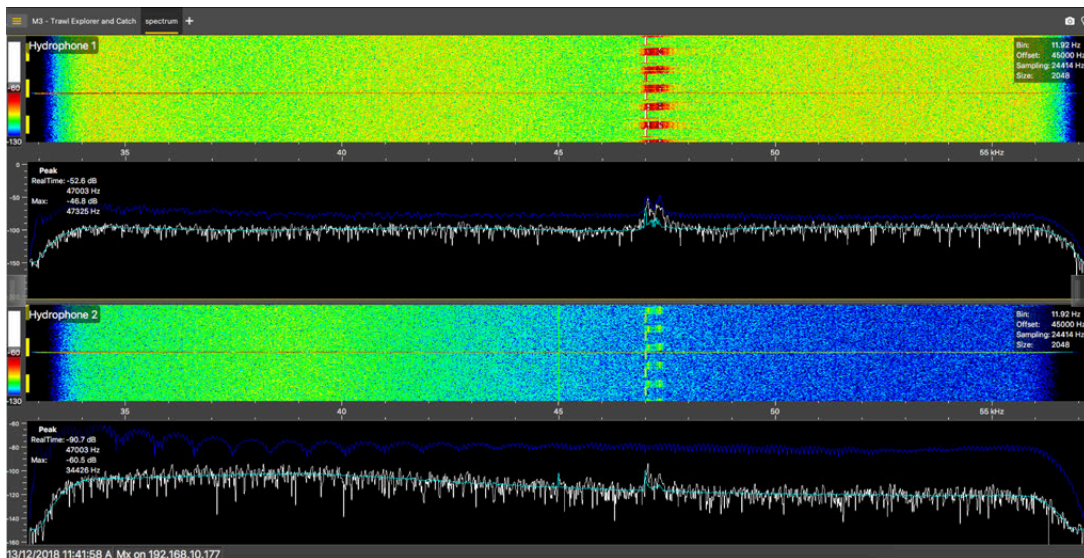

The FFT plot shows three levels of noise in dBV:

- a. **RealTime** (white): level of noise recorded in real time.
- b. **Mean** (cyan): mean recorded level of noise. It is useful to assess the noise floor.
- c. **Max** (dark blue): shows the latest highest level of noise recorded. It is useful to see on which frequencies are the sensors.

The acceptable average level of noise depends on the conditions (distance from the sensor to the hydrophone, fishing method, type of hydrophone). You can have better performance with the following levels:

- Active wideband hydrophone with high/low gain: below -100 dBV
- Active narrowband: NC-1-04 below -80 dBV / NC-1-07 below -100 dBV
- Passive hydrophone: below -110 dBV

6. Scroll on the frequency or dBV scales to zoom in and out.

7. Under **Peak**, you can check:

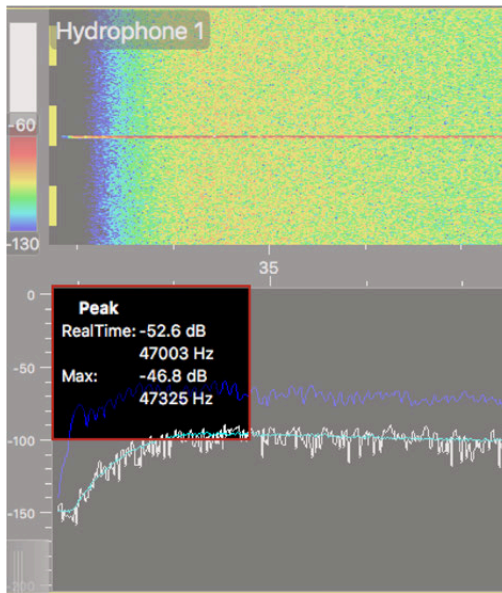

- **RealTime:** the latest highest level of noise (dBV) recorded and its frequency.
- **Max:** the highest level of noise recorded since the beginning of the spectrum and its frequency.

8. Check that there is more than 12 dBV between the maximum noise level (dark blue line) and the average noise level (cyan line) on the peak of sensor frequencies.
9. If you changed the configuration of the hydrophone or sensors, right-click the graph and click **Reset Max** to reset the dark blue line showing the maximum level of noise.
10. To check the maximum, mean and real time measures of noise level at specific frequencies:
 - a. Right-click the FFT plot and click **FFT Marker**.
 - b. Click and drag the marker at a specific point.
Frequency and levels of noise at the marker position are displayed on the right side of the graph.

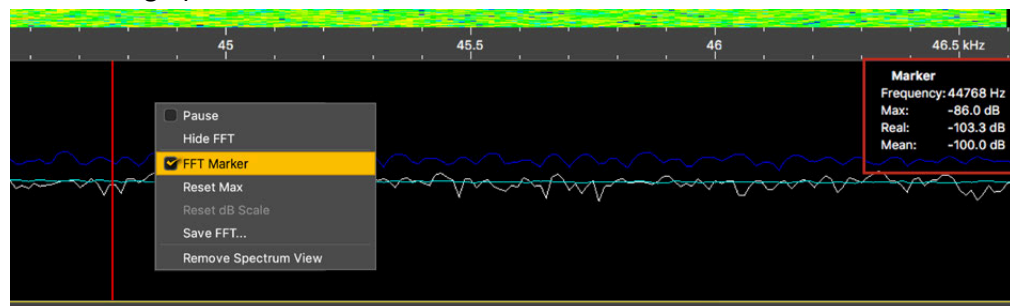

11. Right-click the spectrum and click **Pause** if needed.
12. To save data recorded by the spectrum in a *.txt file, right-click the FFT plot and click **Save FFT**.

The FFT file lists for the entire bandwidth used by the hydrophone (frequencies are in Hz) the maximum and mean levels of noise since the FFT export has started and the last real time level of noise before the export (dBV).

FFT level for Hydrophone 1 of Receiver 192.168.1.153			
Freq	Max	RealTime	Mean
32793	-129.07	-136.64	-138.50
32804	-129.31	-138.41	-139.65
32816	-128.72	-142.89	-139.02
32828	-128.09	-147.78	-139.86
32840	-127.95	-143.07	-140.06

13. Right-click the spectrum analyzer and click **Hide FFT** to hide the FFT plot.
14. Right-click the IP address of the receiver in the status bar and click **Stop Spectrum**.

Troubleshooting

Learn how to solve common problems.

The Mx receiver does not appear on Mosa2 discovery page and the system is not displayed in Scala2

→ The IP addresses of the Mx computer and Mac computer are not on the same subnet.

In order to communicate between each other, and be detected by Mosa2, the IP addresses of both computers need to be on the same subnet. By default, the IP address of the Mx computer is **192.168.1.170**. If the Mac computer is on a different subnet, for example 192.168.**10**.XXX, Mosa2 will not detect the Mx computer.

See **Configuring Mac Mini Network (on page 23)** to know how to change the Mac mini network settings.

→ The system installation on the Mx computer was not done or not properly completed.

1. Connect a screen to the **Display** port on the Mx computer.
2. If the screen does not display the command line **debian login:_** it means that the system is not installed on the Mx computer.
3. See .

No Internet Access

You cannot connect to the internet or see the system control panel page on Firefox web browser.

→ The order of the computer networks might be wrong.

1. From the top left corner of the screen, click **Apple Menu**  > **System Settings**, then click **Network** in the sidebar.
2. If you connect to the internet via a WiFi network, make sure that it is at the top of the list of networks.
3. If using an internet router (port named USB 10/100/1000 LAN), check if it is at the top of list.
4. If not, click the menu on the bottom right corner of the window and select **Set Service Order**.

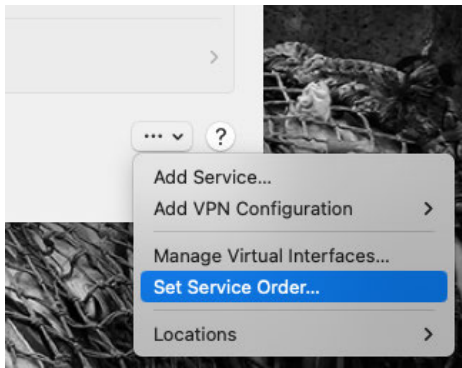

Antifouling system causes interferences

Sonihull™ Ultrasonic Antifouling System causes important noise interference. You can see below an example of spectrum on a hydrophone when Sonihull™ system is off (1) and when it is switched on (2).

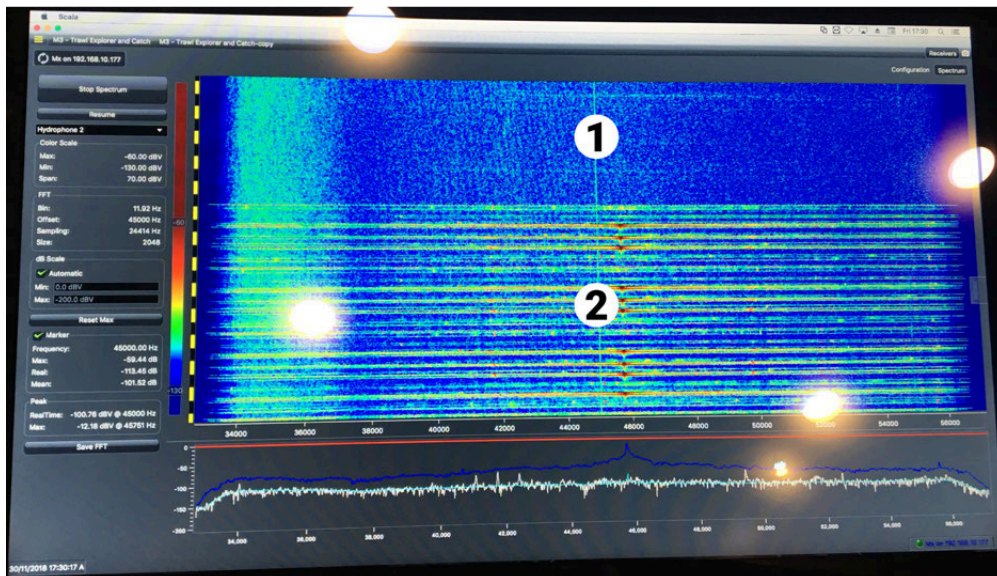

→ You need to switch off Sonihull™ system while fishing.

The Mx computer does not power off immediately

*When the Mx computer restarts after updating the receiver firmware, or after manually restarting it from **Manage Receiver** page on Mosa2, the Mx computer can take up to 1 minute 30 to power off.*

→ Press and hold the power button on the front of the Mx computer for 10 seconds to power it off immediately.

Giving Remote Access to the Computer

If you have an issue with the system, you may need to give remote access to the computer to the support team with **TeamViewer** application.

You need to have access to a good internet connection.

1. From the **Launchpad**  or Dock, click **TeamViewer**.



2. Check that you have the message **Ready to connect** at the bottom left corner of TeamViewer. If the message is **Not ready** it means you have no internet connection.
3. You can give access to your computer to the support team by giving them the ID and Password displayed under **Allow Remote Control**.

Recording Audio Files

If there are issues with the reception of sensor data or with noise interference, the support service may need a recording of the system noise in order to analyze it.

1. Open the control panels and go to the **Mx** panel. Click the menu icon next to the name of the receiver and click **Record Wave file**.

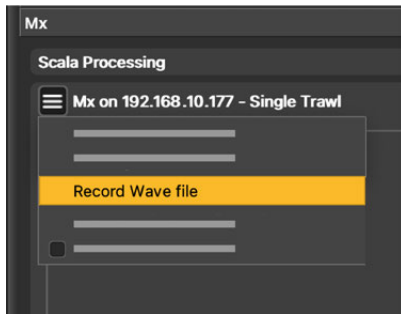

The receiver name becomes yellow. The recording lasts 180 seconds.

2. When the recording is finished, click **OK** to download it.
The audio file is saved in: **Documents/Marport/ScalaLive/(ReceiverIPAddress-Date)/Output**.
3. Send the recording to Marport support service for a diagnosis.

Support Contact

You can contact your local dealer if you need maintenance on your Marport products. You can also ask us at the following contact details:

FRANCE

Marport France SAS
8, rue Maurice Le Léon
56100 Lorient, France
supportfrance@marport.com

ICELAND

Marport EHF
Tónahvarf 7
203 Kopavogur, Iceland
supporticeland@marport.com

NORWAY

Marport Norge A/S
Breivika Industrivei 69
6018 Ålesund, Norway
supportnorge@marport.com

SOUTH AFRICA

Marport South Africa
Cape Town, Western Cape
11 Paarden Eiland Road
Paarden Eiland, 7405
csanter@marport.com

SPAIN

Marport Spain SRL
Camino Chouzo 1
36208 Vigo (Pontevedra), Spain
supportspain@marport.com

UNITED KINGDOM

Marport UK Ltd
32 Wilson Street
Peterhead, AB42 1UD, United Kingdom
gyoungson@marport.com

USA

Marport Americas Inc.
12123 Harbour Reach Drive, Suite 100
Mukilteo, WA 98275, USA
supportusa@marport.com

Appendix

Frequency Plan

It is important to carefully plan the setup of your sensors before adding them to the system. You can create a table with a list of frequencies and complete it when you add sensors.

Frequencies and intervals

The diagrams below show the bandwidth of the different types of Marport sensors and intervals you must respect when adding other sensors.

Figure 1. PRP sensors (e.g. Catch sensor, Trawl Speed, Spread sensor...)

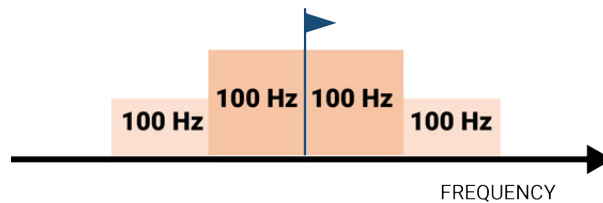

Example: If the frequency of the sensor is 40kHz, there should be no sensors between 39.9 and 40.1kHz.

Figure 2. Marport Pro sensors (e.g. Trident, Door Explorer, Door Sensor Pro, all Navigator range except Catch)

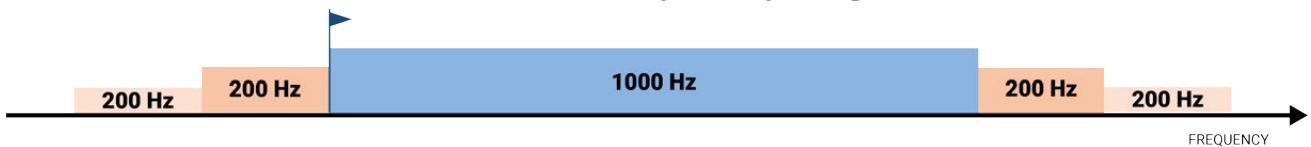

Example: If the frequency of the sensor is 40kHz, there should be no sensors between 39.8 and 41.2kHz.

Figure 3. NBTE sensors (e.g. Speed Explorer, Trawl Explorer, Catch Explorer, Catch Navigator, Door Sounder)

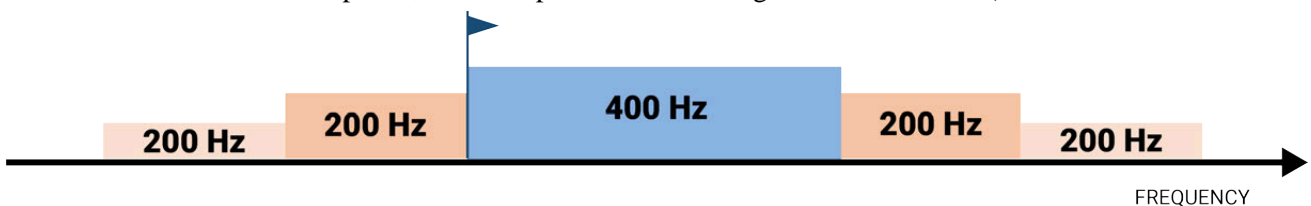

Example: If the frequency of the sensor is 40kHz, there should be no sensors between 39.8kHz and 40.6kHz.

Figure 4. HDTE narrow band mode



Example: If the frequency of the sensor is 40kHz, there should be no sensors between 39.8kHz and 41kHz.

Figure 5. HDTE wide band mode



Example: If the frequency of the sensor is 40kHz, there should be no sensors between 39.8kHz and 42.6kHz.

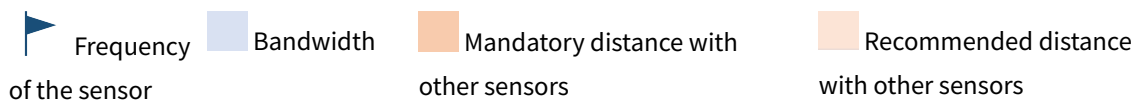

Examples of frequency allocations

- We recommend to allocate frequencies between 34 and 56 kHz for wideband hydrophones and between 41 kHz and 44 kHz for narrowband hydrophones.
- Echosounders are usually placed around 38 kHz, make sure to allow enough distance with them.

Example of a system with Spread, Catch, Trawl Speed sensors and Speed Explorer, Catch Explorer, HDTE and Door Sounder.

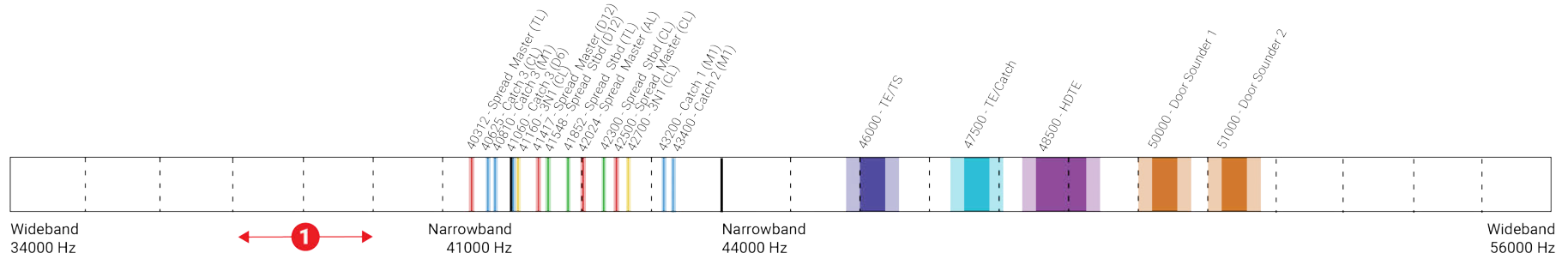

Example of a system with Spread sensors with positioning, Catch sensors, Trawl Explorer and Catch Explorer.

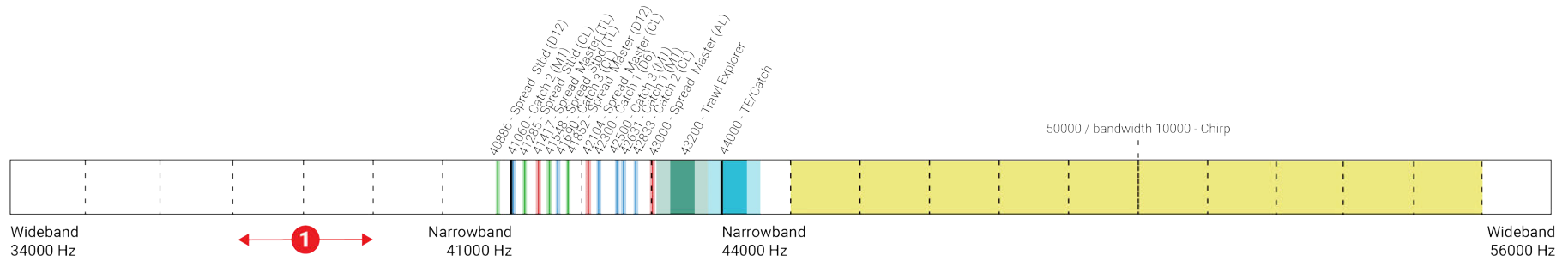

Example of a system for purse seining, with a Seine Explorer and depth Seine sensors.

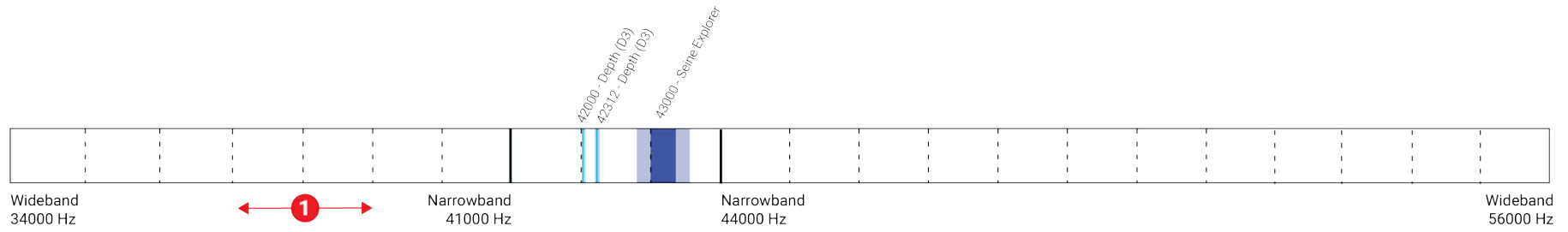

 Bandwidth

 Mandatory distance with other sensors

1 Avoid allocating frequencies between 37 and 39 kHz because this range is generally used by echosounders.

Index

B

Boat code **40**

C

Channel code **40**

Compatibility

macOS **13**

Contact **39**

D

Data recording

Audio recording **37**

F

Frequency plan **40**

H

Hydrophone

Types **25**

I

Interference

Checking **32**

Internet

No access **35**

IP address **23**

Troubleshooting **35**

K

Keyboard

Virtual **16**

M

Mac mini

Installation **20**

Mounting bracket

Installation **20**

N

Network

Mac mini **23**

NMEA converter junction box **27**

P

Power off

Troubleshooting **37**

R

Receiver

Connecting to **27**

H# LEDs **29**

Installation **20**

Lights **29**

PoE LED **29**

Restart

Troubleshooting **37**

S

Sonihull

Interference **36**

Spectrum **32**

T

TeamViewer **37**

Technical specifications **12**
