

M4 System with Mx Computer and Mac Mini

User Manual

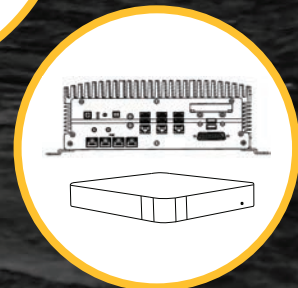

MARPORT

Contents

Legal.....	4
History.....	4
Copyright.....	5
Disclaimer.....	5
Introduction and Presentation.....	6
Introduction.....	6
Safety Guidelines.....	7
Description.....	8
System Overview.....	8
Equipment List.....	8
Technical Specifications.....	11
Compatibility with Apple Operating Systems.....	11
Computer Configuration.....	13
Adding a Virtual Keyboard.....	13
Installation.....	15
Installing the System.....	15
System Cabling.....	15
Powering the Mx computer.....	18
Configuring Mac Mini Network.....	18
Installing Hydrophones.....	20
List of Marport Hydrophones.....	20
Connecting the Hydrophone to the Receiver.....	22
Adding Temperature Data from the Hydrophones to the System.....	23
Understanding Receiver LEDs.....	24
Maintenance and Troubleshooting.....	25
Checking Noise Interference.....	25
Troubleshooting.....	27
The Mx receiver does not appear on Mosa2 discovery page and the system is not displayed in Scala2.....	27
No Internet Access.....	27
Antifouling system causes interferences.....	28
The Mx computer does not power off immediately.....	28
Giving Remote Access to the Computer.....	29
Recording Audio Files.....	29
Support Contact.....	29
Appendix.....	31

Frequency Plan.....31

Index.....36

Legal

History

V1	04/08/19	First release
V2	07/16/20	Now documents Mosa2 version 02.03, Scala version 01.06.34 and Scala2 version 02.02. TE SC sensor is no longer documented in this guide.
V3	03/08/21	<ul style="list-style-type: none"> • Now documents Mosa2 version 02.09.x. • Added guidance on how to prevent computer and receiver from being damaged by water in Installing the System on page 15. • Added contact details for the sales offices in South Africa and Norway in Support Contact on page 29.
V4	01/06/22	<ul style="list-style-type: none"> • Added list of supported Apple operating systems for Scala and Mosa2 in Compatibility with Apple Operating Systems on page 11.
V5	08/04/22	<ul style="list-style-type: none"> • Now documents Scala2 version 02.10.x .
V6	01/13/23	<ul style="list-style-type: none"> • Added product numbers of the two models of the Mx computers in Equipment List on page 8. • Updated Mx computer pictures to the latest model SDS-0-02. • Added guidelines to format Mx computer SDS-0-02. • Updated Ethernet network IP address settings in Configuring Mac Mini Network on page 18. • Added troubleshooting topics: <ul style="list-style-type: none"> • The Mx receiver does not appear on Mosa2 discovery page and the system is not displayed in Scala2 on page 27. • The Mx computer does not power off immediately on page 28

Copyright

© 2023 Marport. All Rights reserved.

No part of this document may be reproduced, stored in a retrieval system or transmitted in any form by any means; electronic, mechanical, photocopying or otherwise, without the express written permission from Marport. “Marport”, the Marport logo and Software Defined Sonar are registered trademarks of Marport. All other brands, products and company names mentioned are the trademark and property of its respective owners only. Marport is a division of Airmar Technology Corporation.

Disclaimer

Marport endeavors to ensure that all information in this document is correct and fairly stated, but does not accept liability for any errors or omissions.

U.S. Patent 9,091,790

Introduction and Presentation

Read this section to get a basic knowledge of your M4 system.

Introduction

The M4 is our heavyweight acoustic receiver, combining the latest digital signal processing with the smartest software. This means that true multifunction channel operation is available and there is no compromise between transmission range and signal detection. We have designed the M4's multifunctional capacity to accommodate a series of full-function channels allowing simultaneous use of standard sensors, net sounders – including narrow band – and high resolution net sounders. All of these are available over an extended frequency range and with selectable configurations for ultramodern net monitoring systems.

The M4 incorporates a host of features that are ready to be implemented, including sensor cross-referencing for positioning and distance, and sensor remote control.

The M4 system works with an Apple Mac mini, an Mx computer and one M4 receiver. The Mx computer processes the signal and displays the data on a screen connected to the Mac. You can configure the sensors and display data to suit your needs.



Safety Guidelines

 **Important:** To ensure proper and safe use of this equipment, carefully read and follow the instructions in this manual.

Description

System Overview

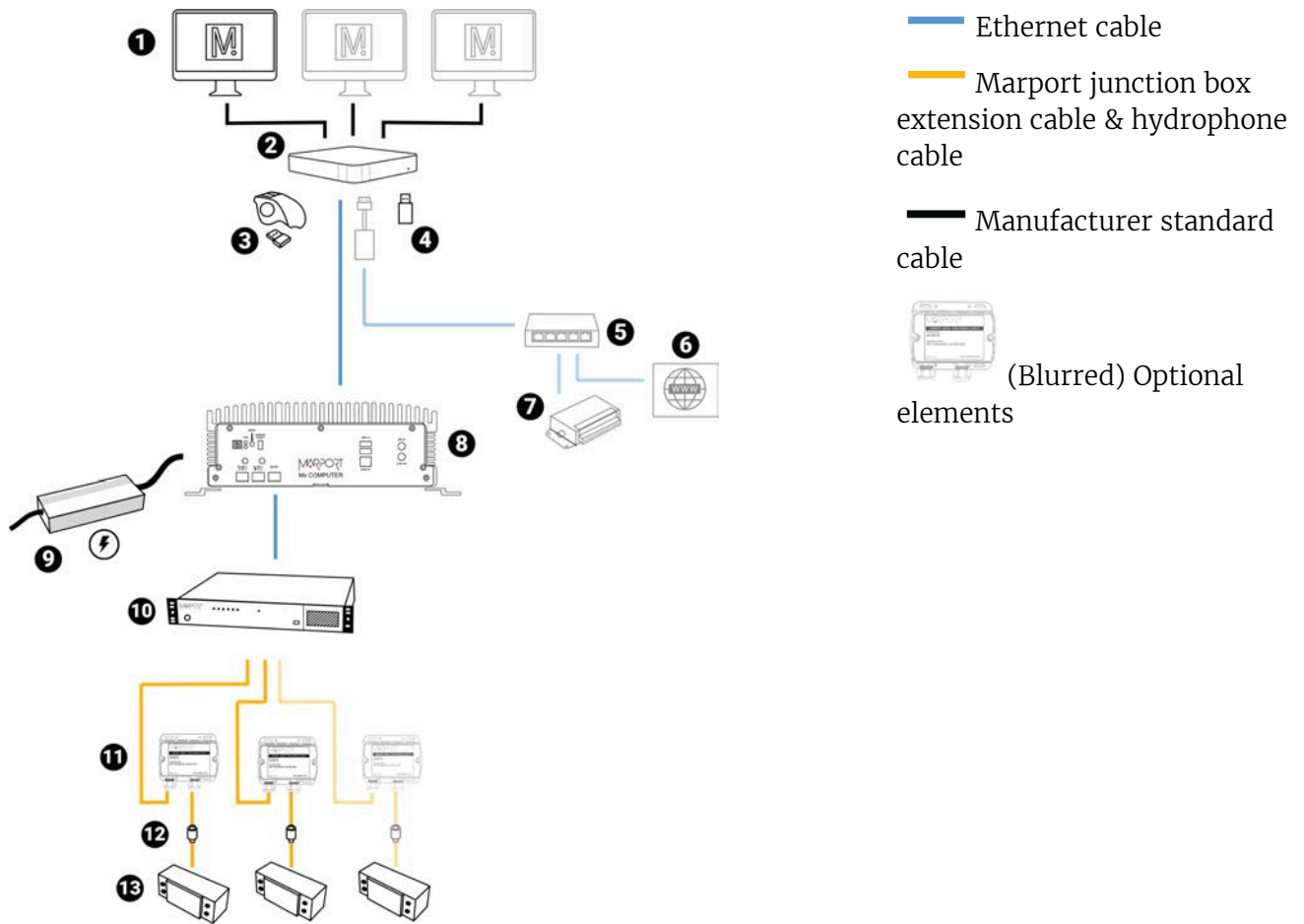

- | | | | |
|---|--------------------------|----|---|
| 1 | Screens | 8 | Mx computer (ref. SDS-0-01/SDS-0-02) |
| 2 | Mac computer | 9 | Power supply (recommended power supply: MEAN WELL HEP-150-24 A) |
| 3 | Wireless trackball mouse | 10 | M4 receiver (ref. M4REC) |
| 4 | Scala2 software dongle | 11 | Junction boxes (x2) (ref. 46-055-01) |
| 5 | Ethernet switch | 12 | Thru-hull penetration (ref. TH-1-XX) |
| 6 | Internet | 13 | Hydrophones (ref. NC-1-XX) |
| 7 | NMEA multiplexer | | |

Equipment List

Here are the hardware and software you need to install a system with a Mx computer.

Computer

- 1 Mac mini
- 1 wireless trackball mouse
- 1 Mac mini power cord
- 2 Thunderbolt to HDMI/VGA/DVI adapters
- 1 Ethernet cable for connection with Mx computer
- 1 Scala2 software dongle

Receiver

- 1 M4 receiver

Mx computer

 **Note:** The Mx computer is delivered with two front plates, with Marport Compact plate already in place. You need to remove it and replace it by the Mx computer plate.

- Mx computer product numbers:

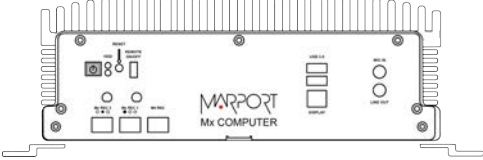
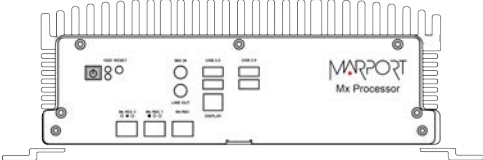
Marport P/N	Airmar P/N	Manufacturer P/N*	Computer front
CMPTR-MX-011222	SDS-0-02	PO boxer-6641	
CMPTR-MX-010419	SDS-0-01	PO boxer-6639M	

*The manufacturer product number is written on a sticker under the computer.

- Power supply: MEAN WELL HEP-150-24 A

Optional Equipment (not included)

- 1 to 3 monitors
- 1 Uninterruptible Power Supply (UPS) to prevent problems if the mains power fails (recommended). Size: 500VA.
- Additional hydrophone junction boxes
- 1 test hydrophone that you can keep on board and connect to the receiver to do functional tests.
- 1 NMEA converter junction box (ref. NC-2-TEMP) to receive temperature data from hydrophones
- 1 NMEA multiplexer to receive NMEA data and display them in Scala2: ShipModul MiniPlex-3E-N2K if using NMEA2000 and NMEA0183 or Miniplex-3E if using only NMEA0183.

- If using Mosa2 on a tablet computer: refer to Marport sales offices to know the recommended model.

Software

Software Application Name	Definition
Marport validated MacOS	Operating system on computer
Scala2	Marport software application collecting, processing, storing and displaying data received from sensors, sounders and other connected devices.
ScalaReplay2	Marport software application replaying data recorded in Scala2.
Mosa2	Marport software application used to configure sensors. Can be used on desktop or tablet computers.
Mozilla Firefox	Web browser. Allows to display the system web page (access to Mx receiver and processor configuration).  Note: Use version 34 available on MASP if you need to import or export the receiver configuration using M4F files.
Java (version 7 or lower)	Only if you need to import or export the receiver configuration using M4F files, via the system web page open in Mozilla Firefox version 34.
FileZilla	File management tool.
TeamViewer	To give remote access of your computer to support service

Technical Specifications

Frequency range	30–60 kHz
Active bandwidth	24 kHz
Number of Rx/Tx channels	6 Rx / 1 Tx
Hydrophones	Up to 6
Bearing to sensor measurement	Yes
Distance to sensor measurement	Yes
Number of simultaneous data reception	100
Number of high resolution sounders (NBTE, HDTE)	10
Temperature input	2 NMEA
Network cables	CAT5e, 100 meters max., U/FTP shielding*

! **Important:** *Make sure to respect these specifications if installing a new Ethernet network cable.

Mx computer

Product reference	PO boxer-6639M
Dimension (W x H x D)	264.2 mm x 186.2 mm x 96.4 mm (10.4" x 3.8" x 6.1")
Weight	4.5 kg (8.8 lb)
Operating temperature	Ambient with Airflow -20°C ~ 50°C
Storage temperature	-45°C ~ 70°C (-49°F ~ 185°F)
Storage humidity	5~95% @ 40°C, non-condensing
Power supply	9 – 36V with 3-pin terminal block

Compatibility with Apple Operating Systems

This topic lists the supported Apple operating systems for Scala2 and Mosa2.

Scala2

OS name	OS release	Scala 1.x	Scala 2.0.x	Scala 2.2.x	Scala 2.4.x	Scala 2.6.x	Scala 2.10.x
Monterey	macOS 12.4				Yes	Yes	Yes
Big Sur	macOS 11.0				Yes	Yes	Yes

OS name	OS release	Scala 1.x	Scala 2.0.x	Scala 2.2.x	Scala 2.4.x	Scala 2.6.x	Scala 2.10.x
Catalina	macOS 10.15		Yes	Yes	Yes	Yes	Yes
Mojave	macOS 10.14	Yes	Yes	Yes	Yes	Yes	Yes
High Sierra	macOS 10.13	Yes	Yes	Yes	Yes	Yes	
Sierra	macOS 10.12	Yes	Yes	Yes	Yes		
El Capitan	OS X 10.11	Yes	Yes	Yes	Yes		
Yosemite	OS X 10.10	Yes					
Mavericks	OS X 10.9	Yes					

Mosa2

OS name	OS release	Mosa 2.0.x	Mosa 2.3.x	Mosa 2.5.x	Mosa 2.7.x	Mosa 2.9.x	Mosa 2.11.x
Monterey	macOS 12.4				Yes	Yes	Yes*
Big Sur	macOS 11.0				Yes	Yes	Yes
Catalina	macOS 10.15	Yes	Yes	Yes	Yes	Yes	Yes
Mojave	macOS 10.14	Yes	Yes	Yes	Yes	Yes	Yes
High Sierra	macOS 10.13	Yes	Yes	Yes	Yes	Yes	Yes
Sierra	macOS 10.12	Yes	Yes	Yes	Yes	Yes	
El Capitan	OS X 10.11	Yes	Yes				
Yosemite	OS X 10.10	Yes	Yes				
Mavericks	OS X 10.9	Yes	Yes				

***Mosa 2.11 compatibility with Monterey:** A1 sensors cannot connect by short range wireless signal. You must use a Configuration Cable.

Computer Configuration

Read this section to learn how to configure the Mac computer.

Adding a Virtual Keyboard

If you do not have a keyboard, you can add a virtual keyboard to the screen and type words using the mouse.

Procedure

1. From the top left corner of the screen, click **Apple Menu**  > **System Preferences** > **Keyboard**.
2. **macOS Big Sur or later:** Click the tab **Input Sources** and select **Show Input menu in menu bar**.

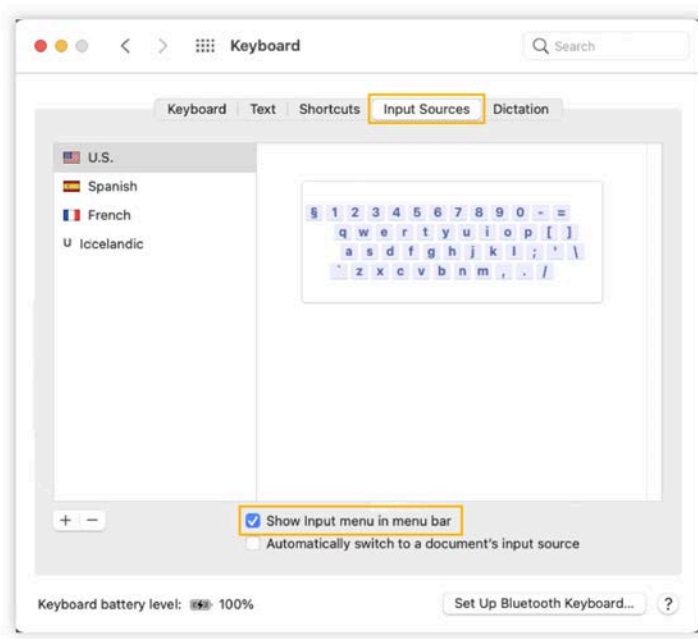

3. **macOS Catalina or earlier:** Select **Show Keyboard, Emoji, & Symbol Viewers in menu bar**.

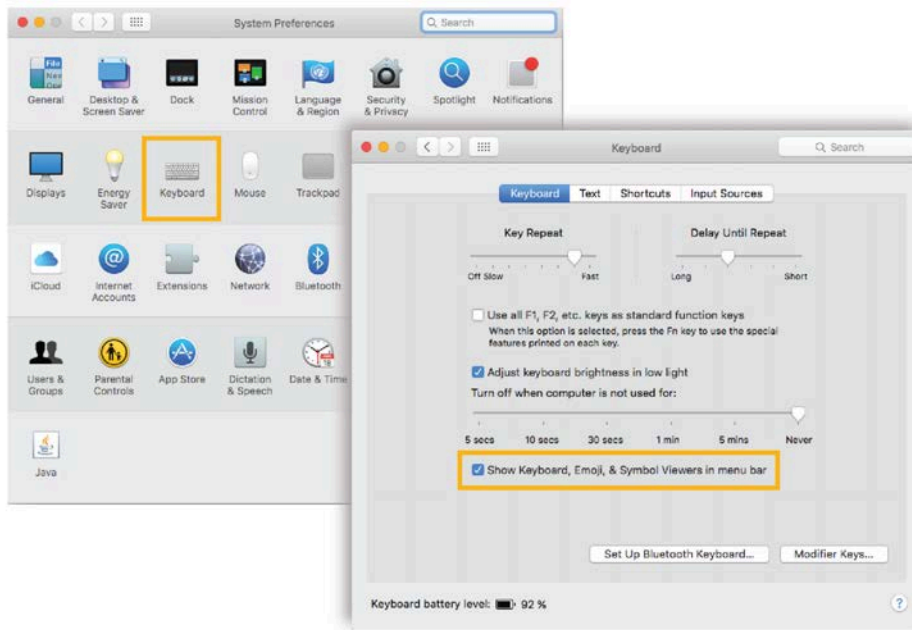

4. Close the window.
5. From the top right corner of the screen, click the flag corresponding to the keyboard language preferences, then select **Show Keyboard Viewer**.



Results

A virtual keyboard is displayed on the screen. You can change its size by dragging its corners.

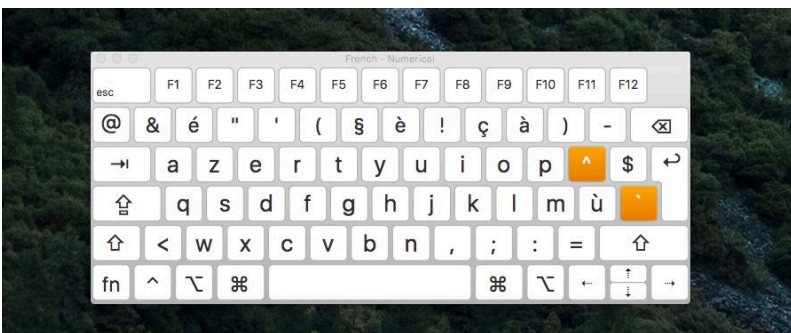

Installation

Read this section to learn how to connect and configure the equipment of the M4 system.

Installing the System

Marport technicians or dealers need to connect the different components of the system.

About this task



Note: The system is installed by Marport or by a dealer. If there is a problem, you can read these installation steps to check the system installation.

Procedure

1. Check that you have all the items needed for the installation (See [Equipment List](#) on page 8)
2. Install the hydrophones and their cables, or find the cables from hydrophones that have already been installed.
3. Route the hydrophone cables toward the junction boxes.
4. Put the receiver elevated in a dry and clean area, as close as possible to the hydrophones. If the receivers are in a closed environment, make sure it is enough ventilated and that the ambient temperature does not exceed 55 °C (131 °F).



Note: Make sure that the cables from the junction boxes are long enough to reach the receiver.

5. Install the Mac computer and Mx computer elevated and/or fixed vertically on a wall, in a dry and ventilated area, without dust, in the wheelhouse.



CAUTION: The receivers are water resistant but not waterproof. The computers are not water resistant. In order to prevent the equipment from being damaged by water:

- Do not install the receiver and computer directly on the floor.
- The cable connectors must not point upwards.

6. Install the monitor(s).
7. Install the loudspeakers, if applicable.
8. Connect the Mac, Mx computer and receiver according to [System Cabling](#) on page 15.
9. You can switch on the computer.
10. Configure the networks and the receiver.
11. Connect the hydrophone cables to the junction boxes and connect the junction boxes to the hydrophone connectors on the receiver. Refer to Hydrophone installation manual for detailed guidelines.
12. When adding sensors to the system, refer to the [Frequency Plan](#) on page 31 to help you allocating frequencies.

System Cabling

Connect the components of the system according to the following cabling.

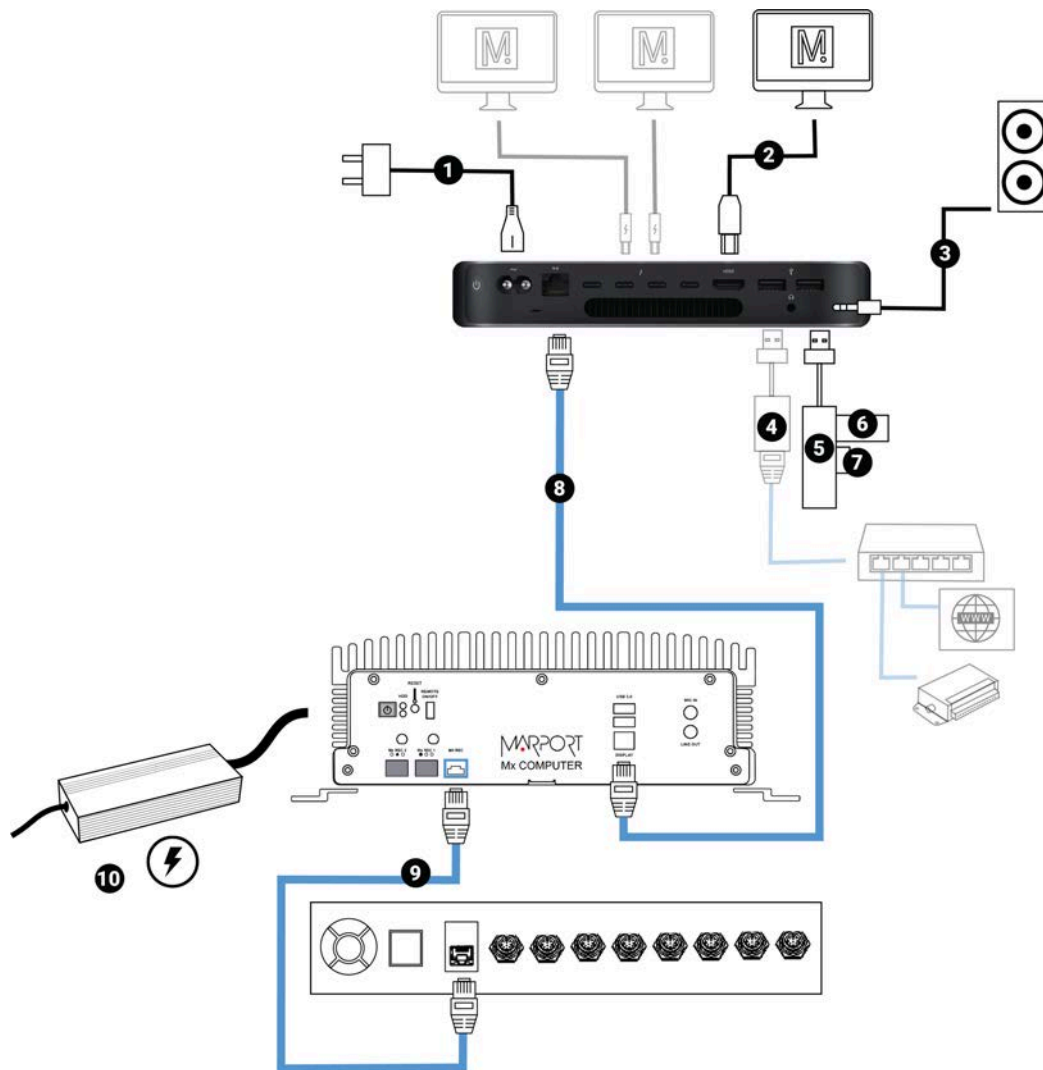

1	Power cable, connected to 100-240V AC power supply*
2	Up to 3 screens (HDMI or thunderbolt cable)
3	Loudspeakers (if applicable)
4	Connection to an Ethernet switch if you need to be connected to both an Internet connection and external devices. Use a USB to Ethernet adapter.
5	USB splitter
6	Scala2 software dongle
7	USB trackball transmitter of the wireless trackball mouse
8	Connection to Mx computer using CAT5e network cable
9	Connection to M4 receiver using CAT5e network cables
10	Power supply (recommended power supply: MEAN WELL HEP-150-24 A)

* We recommend to use an Uninterruptible Power Supply (UPS) to prevent problems if the mains power fails.

Powering the Mx computer

About this task

- !** **Important:** Only use recommended power supply MEAN WELL HEP-150-24 A. Marport cannot not be held responsible for dysfunction of the system if recommended equipment is not used.

Procedure

1. Connect the power cable to the Mx computer.

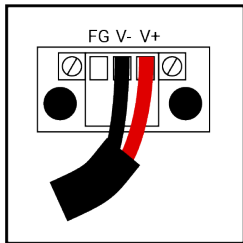



2. Connect MEAN WELL power supply to a power socket.
3. Press  on the Mx computer to switch it on.

Configuring Mac Mini Network

By default, the IP address of the Mx computer is 192.168.1.170. You need to change the IP address of the Ethernet port connected to the Mx computer so the Mac computer can communicate with it.

About this task

 **Note:** If you are moving from a system without the Mx computer, you need to switch off the virtual machine:

- Open VMware Fusion, then click **Virtual Machine** > **Shut Down** in the toolbar.
- Cancel the automatic opening of VMware Fusion: **Apple Menu**  > **System Preferences** > **Users & Groups** > **Login Items** and remove VMware from the list.

Procedure

1. From the top left corner of the screen, click **Apple Menu**  > **System Preferences** > **Network**.
2. If using an internet router, it must be connected to the port named **Apple USB Ethernet Adapter**. In order to connect to the internet, make sure that **Apple USB Ethernet Adapter** network is at the top of the list of networks, then is followed by **Ethernet**. If it is not at the top of the list, click the tooth wheel icon at the bottom of the list and select **Set Service Order**.

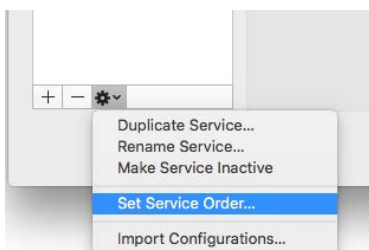

3. In the network list, click **Ethernet**, then:
 - a) In **Configure IPv4** menu select **Manually**.
 - b) In **IP Address**, enter 192.168.1.165.
 - c) In **Router**, enter 192.168.1.1.

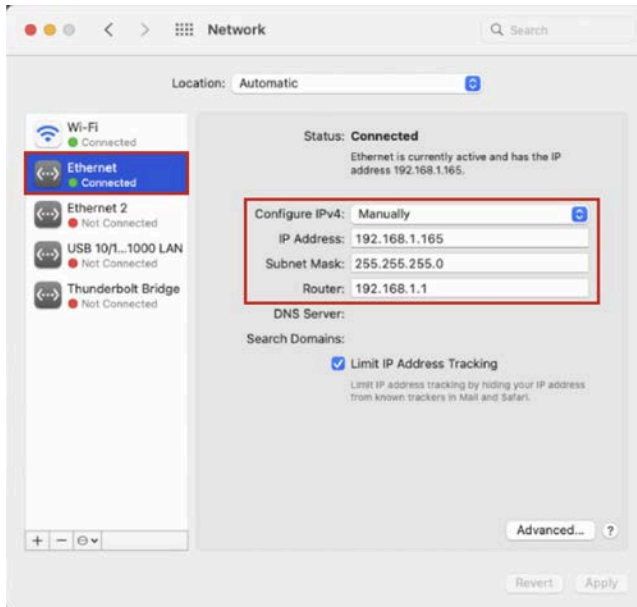

4. Click **Apply**.

Installing Hydrophones

You need to connect hydrophones to the system.



Note: For more information about Marport hydrophones, please refer to Hydrophone Installation Manual.

List of Marport Hydrophones

These are technical specifications for hydrophones currently sold by Marport. For information about obsolete hydrophones, please contact Marport support.

Product reference	Name	Use case	Bandwidth (3 dB)	Typical current consumption	Cable*
NC-1-05	Passive wideband hydrophone (no preamplifier)	<ul style="list-style-type: none"> Vessel with very low level of noise (below -110 dBV). Sensors close to the vessel (approx. 300 m) For positioning systems with Slant Range/pinger (one passive hydrophone is necessary for transmission). 	33-60 KHz	0.0 mA	Blue
NC-1-05 + NC-2-02	Passive hydrophone + Wideband preamplifier box	<ul style="list-style-type: none"> Vessel with normal level of noise (below -100 dBV). Large number of sensors.† Use at great depths (> 500 m). Gain configurable (Low or High) Filters configurable (38 and/or 50kHz). Low noise environment between passive hydrophone and wideband preamplifier box 	33-60 KHz	25-29 mA	Blue

Product reference	Name	Use case	Bandwidth (3 dB)	Typical current consumption	Cable*
NC-1-07	Active hydrophone (integrated preamplifier)	<ul style="list-style-type: none"> • Vessel with normal level of noise (below -100 dBV). • Limited number of sensors.† • No filtering options. • Not used for positioning system 	41-44 KHz	4-6 mA	Green
NC-1-06	Active wideband hydrophone (integrated preamplifier)	<ul style="list-style-type: none"> • Vessel with normal level of noise (below -100 dBV). • Large number of sensors.† • Use at great depths (> 500 m). • Gain configurable (Low or High) • Filters configurable (38 and/or 50kHz) 	30-60 KHz	25-29 mA	Yellow
NC-1-08	Active wideband hydrophone (integrated preamplifier)	<ul style="list-style-type: none"> • Vessel with normal level of noise (below -100 dBV). • Large number of sensors.† • Use at great depths (> 500 m). • Gain configurable (Low or High) • Filters configurable (38 and/or 50kHz) 	30-60 KHz	18-22 mA	Yellow

Product reference	Name	Use case	Bandwidth (3 dB)	Typical current consumption	Cable*
NC-1-09 ‡	Active hydrophone (integrated preamplifier)	<ul style="list-style-type: none"> • For use on a paravane only • Vessel with normal level of noise (below -100 dBV). • Limited number of sensors.† • No filtering options. • Not used for positioning system 	41-44 KHz	4-6 mA	Blue, heavy-duty

*Note that cables are colored according to the type of hydrophone: blue for passive, green for active narrowband and yellow for active wideband.

† Standard active hydrophones have an available bandwidth of 6kHz. So, if: $(PRP_number * 100) + (NBTE_number * 800) < 6000$ you have enough place. If: $(PRP_number * 100) + (NBTE_number * 800) > 6000$ then you need a wideband hydrophone.

‡ Add as NC-1-07 in the system web page.

Connecting the Hydrophone to the Receiver

You need to connect the hydrophone to the receiver to be able to display sensor data received by the hydrophones.

Procedure

- Connect the extension cable of the junction box to a hydrophone input on the receiver:
 - Using an NMEA converter junction box (P/N: NC-2-TEMP), connect to the hydrophone input 1 or 2 at the back of the receiver to be able to receive water temperature from Marport hydrophones.



Note: Hydrophone inputs 1 and 2 allow to receive temperature from an NMEA connection, so you need an NMEA converter junction box. If you connect to other hydrophone inputs or have no NMEA converter, you will not have temperature data from Marport hydrophones.

Adding Temperature Data from the Hydrophones to the System

You can add the hydrophone to the receiver as a sensor in order to display in Scala2 the temperature of the water surface.

Before you begin

- ! Important:** In order to receive temperature data, make sure the hydrophone is connected to an NTC input on the receivers or is connected using an NMEA converter junction box. See [Connecting the Hydrophone to the Receiver](#) on page 22 for guidelines.

Procedure

1. From Scala2, click **Menu**  > **Expert Mode** and enter the password `copernic`.
2. Right-click the IP address of the receiver at the bottom of the page, then click **Configure Receiver**.
3. From the left side of the page, click **Sensors**.

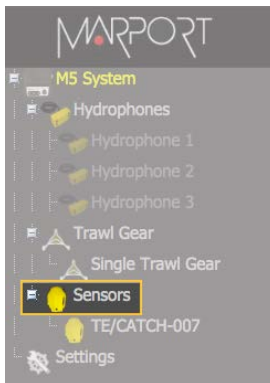

4. Under **Add Sensor Product**:
 - a) Select **Hydrophone** in the **Product Category** menu.
 - b) In the **Product Name** menu, select **NMEA temperature** if using an NMEA converter junction box, or **NTC temperature** if the hydrophone is connected to an NTC input.
 - c) In **Hydrophone Location**, select the number of the receiver's port on which the hydrophone is connected.

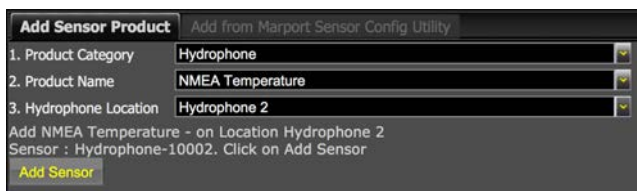

- d) Click **Add Sensor**.

Results

The water temperature is displayed in Scala2, in the control panels, under **Mx**.

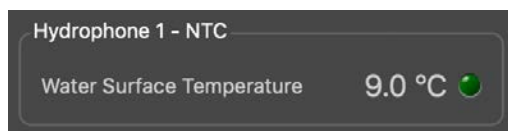
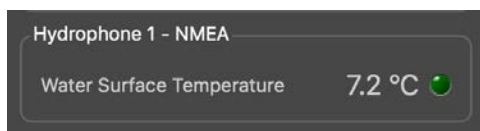

Understanding Receiver LEDs



Boot sequence

When you power on the receiver, the LEDs on the receiver must light up the following way:

- Hydrophone LEDs become blue / red / green.
- LED in the letter A becomes blue / green / red, then stays red.
- When data are emitted or received, ETH LED blinks green.

Hydrophone LEDs

The LEDs on the hydrophone inputs identify the type of hydrophone that is connected to the receiver.

- Blue: passive hydrophone
- Red: active hydrophone
- No light: no configured hydrophone

Maintenance and Troubleshooting

Read this section for troubleshooting and maintenance information.

Checking Noise Interference

Use the spectrum analyzer to check the noise level of the hydrophones and check for interference.

Procedure

1. Click Add + to create a new page on which you will add the spectrum analyzer(s).
2. Right-click the IP address of the receiver in the status bar and click **Start Spectrum**.

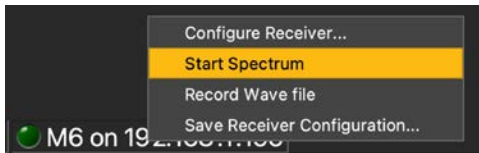

3. Open the control panels and go to the **Mx** panel.
4. Go to **Hydrophone** data, then drag and drop **Spectrum** data to a page. These data appear only when the spectrum has been started.



5. The spectrum analyzer is displayed. You can display up to 6 spectrum analyzers at the same time. Below is an example of a page with two spectrum analyzers.

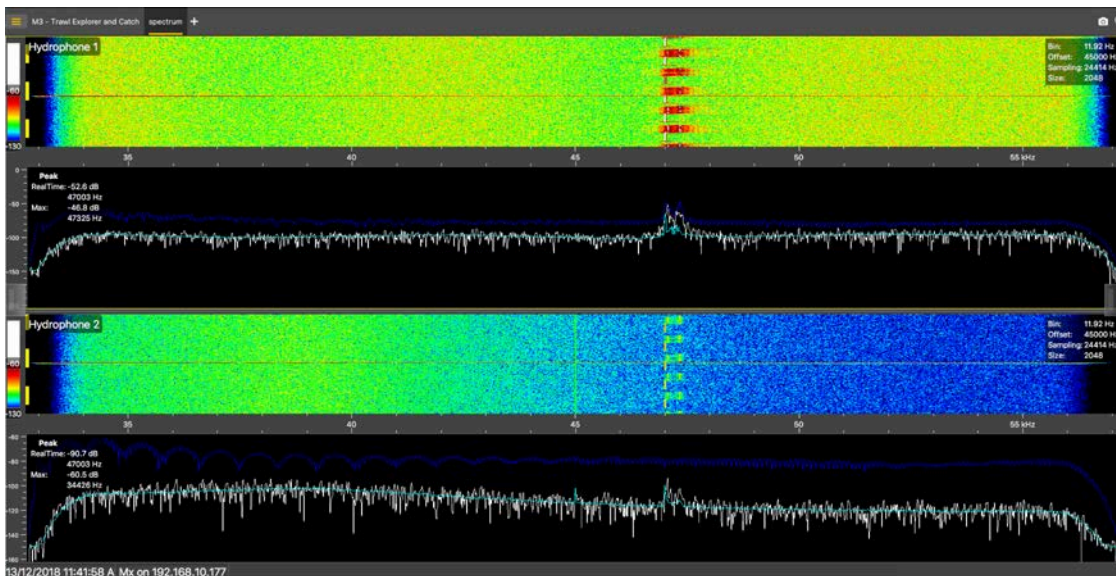

The FFT plot shows three levels of noise in dBV:

1. **RealTime** (white): level of noise recorded in real time.
2. **Mean** (cyan): mean recorded level of noise. It is useful to assess the noise floor.

3. **Max** (dark blue): shows the latest highest level of noise recorded. It is useful to see on which frequencies are the sensors.

The acceptable average level of noise depends on the conditions (distance from the sensor to the hydrophone, fishing method, type of hydrophone). You can have better performance with the following levels:

- Active wideband hydrophone with high/low gain: below -100 dBV
- Active narrowband: NC-1-04 below -80 dBV / NC-1-07 below -100 dBV
- Passive hydrophone: below -110 dBV

6. Scroll on the frequency or dBV scales to zoom in and out.

7. Under **Peak**, you can check:

- **RealTime**: the latest highest level of noise (dBV) recorded and its frequency.
- **Max**: the highest level of noise recorded since the beginning of the spectrum and its frequency.

8. Check that there is more than 12 dBV between the maximum noise level (dark blue line) and the average noise level (cyan line) on the peak of sensor frequencies.

9. If you changed the configuration of the hydrophone or sensors, right-click the graph and click **Reset Max** to reset the dark blue line showing the maximum level of noise.

10. To check the maximum, mean and real time measures of noise level at specific frequencies:

- a) Right-click the FFT plot and click **FFT Marker**.
- b) Click and drag the marker at a specific point.

Frequency and levels of noise at the marker position are displayed on the right side of the graph.

11. Right-click the spectrum and click **Pause** if needed.

12. To save data recorded by the spectrum in a *.txt file, right-click the FFT plot and click **Save FFT**.

The FFT file lists for the entire bandwidth used by the hydrophone (frequencies are in Hz) the maximum and mean levels of noise since the FFT export has started and the last real time level of noise before the export (dBV).

FFT level for Hydrophone 1 of Receiver 192.168.1.153			
Freq	Max	RealTime	Mean
32793	-129.07	-136.64	-138.50
32804	-129.31	-138.41	-139.65
32816	-128.72	-142.89	-139.02
32828	-128.09	-147.78	-139.86
32840	-127.95	-143.07	-140.06

13. Right-click the spectrum analyzer and click **Hide FFT** to hide the FFT plot.

14. Right-click the IP address of the receiver in the status bar and click **Stop Spectrum**.

Troubleshooting

Learn how to solve common problems.

The Mx receiver does not appear on Mosa2 discovery page and the system is not displayed in Scala2

→ The IP addresses of the Mx computer and Mac computer are not on the same subnet.

In order to communicate between each other, and be detected by Mosa2, the IP addresses of both computers need to be on the same subnet. By default, the IP address of the Mx computer is **192.168.1.170**. If the Mac computer is on a different subnet, for example 192.168.**10**.XXX, Mosa2 will not detect the Mx computer.

See [Configuring Mac Mini Network](#) on page 18 to know how to change the Mac mini network settings.

→ The system installation on the Mx computer was not done or not properly completed.

1. Connect a screen to the **Display** port on the Mx computer.
2. If the screen does not display the command line **debian login: _** it means that the system is not installed on the Mx computer.
3. See [or](#) , according to the model of the Mx computer.

No Internet Access

You cannot connect to the internet or see the system control panel page on Firefox web browser.

→ The order of the computer networks is wrong.

1. From the top left corner of the screen, click **Apple Menu**  > **System Preferences** > **Network**.
2. Make sure that the network called Ethernet 2 is at the top of the list, then is followed by the network called Ethernet 1.

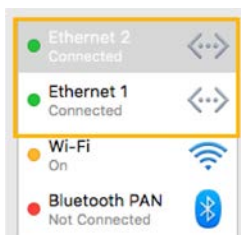

3. If not, to change the order click the tooth wheel icon at the bottom of the list and select **Set Service Order**.

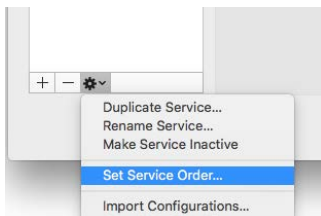

Antifouling system causes interferences

Sonihull™ Ultrasonic Antifouling System causes important noise interference. You can see below an example of spectrum on a hydrophone when Sonihull™ system is off (1) and when it is switched on (2).

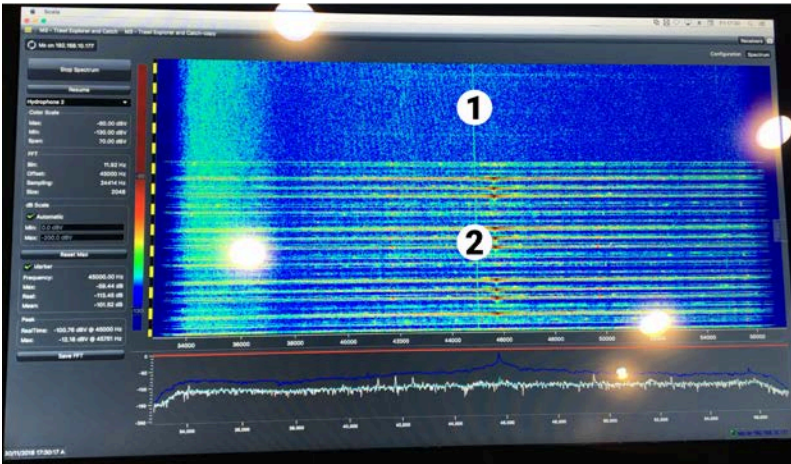

→ You need to switch off Sonihull™ system while fishing.

The Mx computer does not power off immediately

When the Mx computer restarts after updating the receiver firmware, or after manually restarting it from **Manage Receiver** page on Mosa2, the Mx computer can take up to 1 minute 30 to power off.

→ Press and hold the power button on the front of the Mx computer for 10 seconds to power it off immediately.

Giving Remote Access to the Computer

If you have an issue with the system, you may need to give remote access to the computer to the support team with **TeamViewer** application.

Before you begin

You need to have access to a good internet connection.

Procedure

1. From the **Launchpad**  or Dock, click **TeamViewer**.



2. Check that you have the message **Ready to connect** at the bottom left corner of TeamViewer. If the message is **Not ready** it means you have no internet connection.
3. You can give access to your computer to the support team by giving them the ID and Password displayed under **Allow Remote Control**.

Recording Audio Files

If there are issues with the reception of sensor data or with noise interference, the support service may need a recording of the system noise in order to analyze it.

Procedure

1. From the lower right corner of Scala2 window, right-click the receiver name, then click **Record WAV Files**.

The receiver name becomes yellow. The recording lasts 180 seconds.

2. Open the control panels and go to the **Mx** panel. Click the menu icon next to the name of the receiver and click **Record Wave file**.

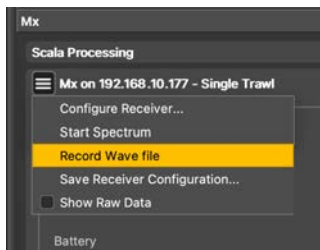

3. When the recording is finished, click **OK** to download it.

The audio file is saved in:

4. Send the recording to Marport support service for a diagnosis.

Support Contact

You can contact your local dealer if you need maintenance on your Marport products. You can also ask us at the following contact details:

FRANCE

Marport France SAS
8, rue Maurice Le Léon
56100 Lorient, France
supportfrance@marport.com

NORWAY

Marport Norge A/S
Breivika Industrivei 69
6018 Ålesund, Norway
supportnorge@marport.com

SPAIN

Marport Spain SRL
Camino Chouzo 1
36208 Vigo (Pontevedra), Spain
supportspain@marport.com

USA

Marport Americas Inc.
12123 Harbour Reach Drive, Suite 100
Mukilteo, WA 98275, USA
supportusa@marport.com

ICELAND

Marport EHF
Tónahvarf 7
203 Kopavogur, Iceland
supporticeland@marport.com

SOUTH AFRICA

Marport South Africa
Cape Town, Western Cape
11 Paarden Eiland Road
Paarden Eiland, 7405
csanter@marport.com

UNITED KINGDOM

Marport UK ltd
32 Wilson Street
Peterhead, AB42 1UD, United Kingdom
gyoungson@marport.com

Appendix

Frequency Plan

It is important to carefully plan the setup of your sensors before adding them to the system. You can create a table with a list of frequencies and complete it when you add sensors.

Boat & Channel Codes

This list shows the standard frequencies for PRP telegrams. When you configure boat codes, make sure to respect the correct interval between frequencies (see table above).

Codes		
BC/CH	Frequency	FID (Scanmar)
C-1/CH1	42833	45
C-1/CH2	41548	32
C-1/CH3	41852	35
C-1/CH4	40810	25
C-1/CH5	42500	42
C-1/CH6	43200	49
C-2/CH1	42631	43
C-2/CH2	41417	31
C-2/CH3	41690	33
C-2/CH4	40886	26
C-2/CH5	42300	40
C-2/CH6	43100	48
C-3/CH1	42429	41
C-3/CH2	41285	30
C-3/CH3	41548	32
C-3/CH4	40970	27
C-3/CH5	42100	38
C-3/CH6	43000	47
C-4/CH1	42226	39
C-4/CH2	41852	35
C-4/CH3	41417	31
C-4/CH4	41160	29

C-4/CH5	42700	44
C-4/CH6	43300	50
C-5/CH1	42024	37
C-5/CH2	41690	33
C-5/CH3	41285	30
C-5/CH4	41060	28
C-5/CH5	42900	46
C-5/CH6	43400	51
C-6/CH1	39062	3
C-6/CH2	39375	7
C-6/CH3	39688	11
C-6/CH4	40000	15
C-6/CH5	40312	19
C-6/CH6	40625	23
C-7/CH1	38906	1
C-7/CH2	39219	5
C-7/CH3	39531	9
C-7/CH4	39844	13
C-7/CH5	40156	17
C-7/CH6	40469	21

Frequencies and intervals

The diagrams below show the bandwidth of the different types of Marport sensors and intervals you must respect when adding other sensors.

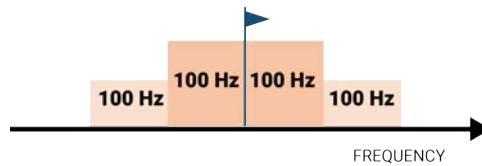

Figure 1: PRP sensors (e.g. Catch sensor, Trawl Speed, Spread sensor...)

Example: If the frequency of the sensor is 40kHz, there should be no sensors between 39.9–40kHz and 40–40.1kHz.

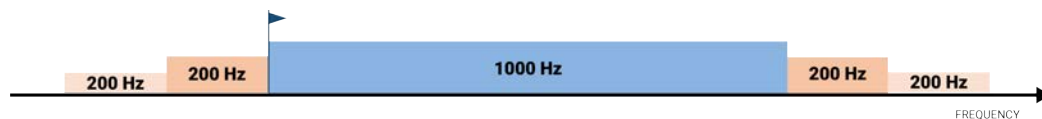

Figure 2: Marport Pro sensors (e.g. Trident, Door Explorer, Trawl Navigator, Speed Navigator)

Example: If the frequency of the sensor is 40kHz, there should be no sensors between 39.8–40kHz and 40–50.2kHz.

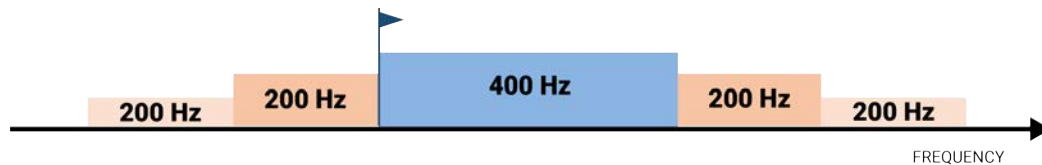

Figure 3: NBTE sensors (e.g. Speed Explorer, Trawl Explorer, Catch Explorer, Catch Navigator, Door Sounder)

Example: If the frequency of the sensor is 40kHz, there should be no sensors between 39.8–40kHz and 40–40.6kHz.

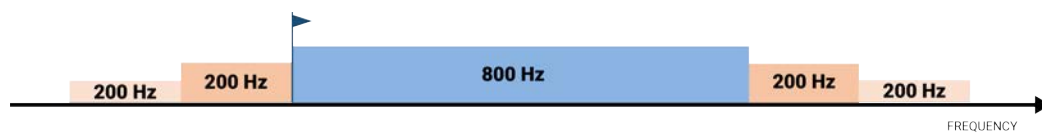

Figure 4: HDTE narrow band mode

Example: If the frequency of the sensor is 40kHz, there should be no sensors between 39.8–40kHz and 40–41kHz.

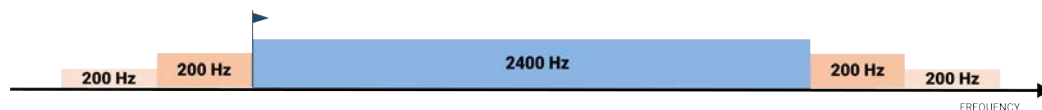

Figure 5: HDTE wide band mode

Example: If the frequency of the sensor is 40kHz, there should be no sensors between 39.8–40kHz and 40–42.6kHz.

▶ Frequency of the sensor ■ Bandwidth ■ Mandatory distance with other sensors ■ Recommended distance with other sensors

Examples of frequency allocations

- We recommend to allocate frequencies between 34 and 56 kHz for wideband hydrophones and between 41 kHz and 44 kHz for narrowband hydrophones.
- Echosounders are usually placed around 38 kHz, make sure to allow enough distance with them.

Example of a system with Spread, Catch, Trawl Speed sensors and Speed Explorer, Catch Explorer, HDTE and Door Sounder.

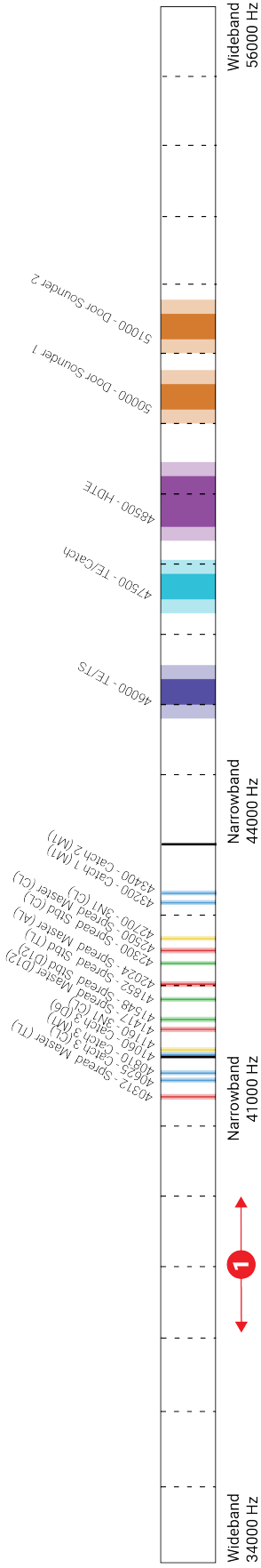

Example of a system with Spread sensors with positioning, Catch sensors, Trawl Explorer and Catch Explorer.

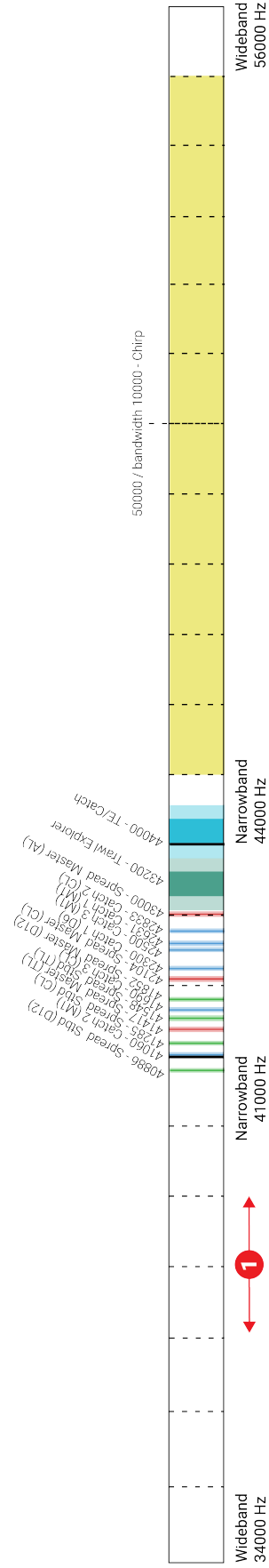

Example of a system for purse seining, with a Seine Explorer and depth Seine sensors.

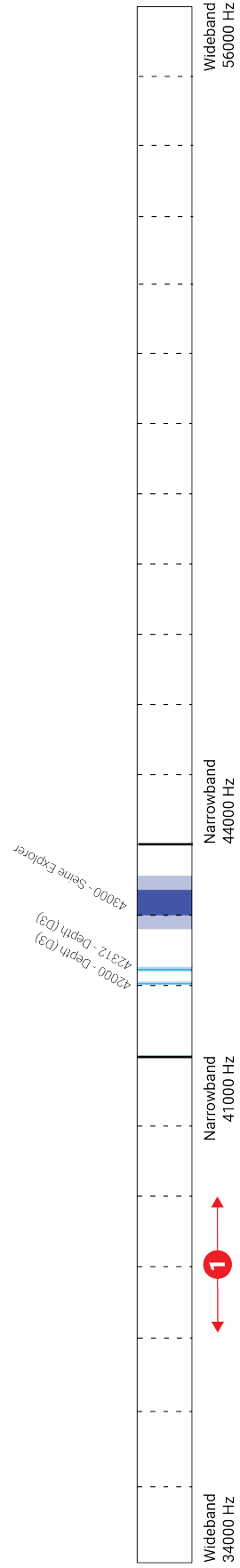

- Bandwidth
- Mandatory distance with other sensors

1 Avoid allocating frequencies between 37 and 39 kHz because this range is generally used by echosounders.

Index

B

Boat code [31](#)

C

Channel code [31](#)

D

Data recording
 Audio recording [29](#)

F

Frequency plan [31](#)

H

Hydrophone
 Types [20](#)

I

Interference
 Checking [25](#)
Internet
 No access [27](#)
IP address [18](#)
 Troubleshooting [27](#)

K

Keyboard
 Virtual [13](#)

M

Mac pro
 Installation [15](#)

N

Network
 Mac Pro [18](#)
NMEA converter junction box [22](#)

P

Power off
 Troubleshooting [28](#)

R

Receiver
 Connecting to [22](#)
 ETH LED [24](#)
 H# LEDs [24](#)
 Installation [15](#)
 Lights [24](#)
Restart
 Troubleshooting [28](#)

S

Sonihull
 Interference [28](#)
Spectrum [25](#)

T

TeamViewer [29](#)
Technical specifications [11](#)