

PRP Spread Sensors User Manual



MARPORT

Contents

Legal.....	5
History.....	5
Copyright.....	6
Disclaimer.....	6
Introduction and Presentation.....	7
Introduction.....	7
Safety Guidelines.....	8
About PRP Spread sensors.....	9
About Trawl Positioning.....	11
Description.....	14
System Compatibility.....	14
Technical Specifications.....	14
Main Parts.....	15
PRP Spread Sensor.....	15
Operational Mode Indicator.....	16
Sensor Configuration.....	17
Connecting the Sensor to Mosa2.....	17
Using a Dock Charger Plug.....	17
Using the Configuration Cable.....	18
Battery Information.....	19
Configuring Door Spread Settings.....	19
Configuring the Trawl Node.....	20
Configuring the Uplink Frequency and Power.....	21
Configuring PRP Spread Sensors Telegrams.....	21
Configuring Positioning Signal Settings.....	23
Calibrating the Pitch and Roll.....	23
Calibrating Automatically.....	24
Applying Offsets to Measurements.....	25
Testing Measures.....	26
Saving a Configuration on Mosa2.....	27
Exporting Sensor Configuration.....	29
Importing a Sensor Configuration.....	30
System Configuration and Display.....	31
Adding the Sensors to the Receiver.....	31
Adding the Sensors to the Receiver.....	31
Configuring Sensor Settings.....	31
Configuring the System with the Positioning Option.....	33
Configuring the Positioning Settings.....	33
Calculations for the Positioning System.....	34

Configuring Trawl Settings.....	35
Adding Data from External Devices.....	36
Receiving Warp Lengths from Scantrol.....	39
Configuring Data Display on Scala2.....	41
Displaying Trawl Door 3D View.....	41
Displaying Data from Multiple Trawls.....	44
Using the MultiTrawl View on Scala2.....	48
Displaying the MultiTrawl View.....	48
Display Options.....	49
Understanding the MultiTrawl View.....	52
Displaying Door Positioning Data.....	54
Doors Positioning Data.....	54
Displaying the Chart View.....	55
Bearing Angles.....	56
Changing the Number of Trawls.....	57
Installation.....	60
Installation Principles.....	60
Installing Sensor Pockets.....	63
Maintenance and Troubleshooting.....	66
Charging the Sensor with the Dock.....	66
Cleaning the Sensor.....	67
Maintenance Checklist.....	68
Troubleshooting.....	69
Mosa2 does not open due to error message.....	69
Sensor does not connect correctly with Mosa2 when using the Configuration Cable.....	69
Chart and 3D Views Are Wrong.....	70
The trawl is placed incorrectly.....	70
There is no trawl on Scala2, MaxSea or Olex.....	70
There is no trawl or vessel.....	71
The trawl seems shrunken.....	71
The vessel and trawl have erratic movements: they jump, zigzag, move forward and backward.....	71
Positioning on SeapiX: Port/starboard trawl doors are reversed.....	71
In Scala2, Lost is displayed instead of spread distance.....	72
Support Contact.....	73
Appendix.....	74
Frequency Plan.....	74
Compatible NMEA Sentences from Winch Control Systems, GPS and Compass Devices.....	79
Pocket Drawings.....	87
Pocket Angle of Attack.....	88
Pocket for XL Bottles.....	89
Pocket for Stubby Bottles.....	96
Pocket for Stubby Bottles with Slim Housing.....	100

General Installation Instructions and Drawings..... 101

Index..... 102

Legal

History

V1	04/19/22	First release
V2	08/04/22	<ul style="list-style-type: none">• Now documents Scala2 version 02.10.x and Mosa2 version 02.11.x.• Added frequency bandwidth schemas in Frequency Plan on page 74.

Copyright

© 2022 Marport. All Rights reserved.

No part of this document may be reproduced, stored in a retrieval system or transmitted in any form by any means; electronic, mechanical, photocopying or otherwise, without the express written permission from Marport. “Marport”, the Marport logo and Software Defined Sonar are registered trademarks of Marport. All other brands, products and company names mentioned are the trademark and property of its respective owners only. Marport is a division of Airmar Technology Corporation.

Disclaimer

Marport endeavors to ensure that all information in this document is correct and fairly stated, but does not accept liability for any errors or omissions.

The present user guide is applicable for the following versions:

- Mosa2: 02.11.x
- Scala2: 02.10.x

If you use other versions, the visual interface and options may vary.

Introduction and Presentation

Get a basic knowledge of the sensor.

Introduction

The PRP Spread sensors are part of a new generation of Marport sensors. they send the spread distance between the doors and clumps, depth, pitch, roll, water temperature and optionally positioning measurements using the PRP communication protocol technology.

The sensors can be installed on single, twin, triple and quadruple trawls. Door and clump alignment can be monitored thanks to a real time 3D view of the trawl gear on Scala2 application.

They are compatible with Marport Dock product, with which you can easily charge, monitor, configure and update the connected sensors (up to 4).

Safety Guidelines

 **Important:** To ensure proper and safe use of this equipment, carefully read and follow the instructions in this manual.

Basic good practices

Never place the product in a hazardous and/or flammable atmosphere.

Product installation and use

Install and use this product in accordance with this user manual. Incorrect use of the product may cause damage to the components or void the warranty.

Only qualified Marport dealers can do maintenance and repairs on internal components of the sensors.

Precautions

 **Warning:** In case of water ingress in the product, do not charge it: battery may vent or rupture, causing product or physical damage.

About PRP Spread sensors

Overview of the installation on the trawl gear

Spread sensors (PRP and Digital) and Door Explorer sensors can be mixed on a same installation.

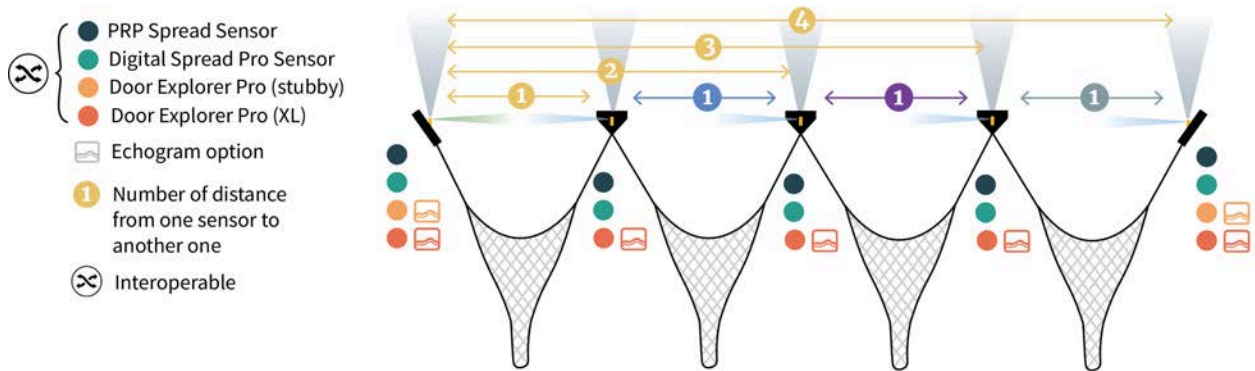

! Important: You cannot mix Spread and Door Explorer sensors with A1 and Duplex sensors on a same door spread installation because they cannot communicate with each others.

Spread sensors

PRP Spread sensors can use the PRP (Pulse Repetition Period) communication protocol: you must set a telegram and a frequency to each data received from the sensor. The sensor has a longer battery life than with a digital communication protocol.

The sensors send data such as temperature, depth, pitch and roll to the receiver. The positioning option can be added to measure the bearing.

Single trawl communication

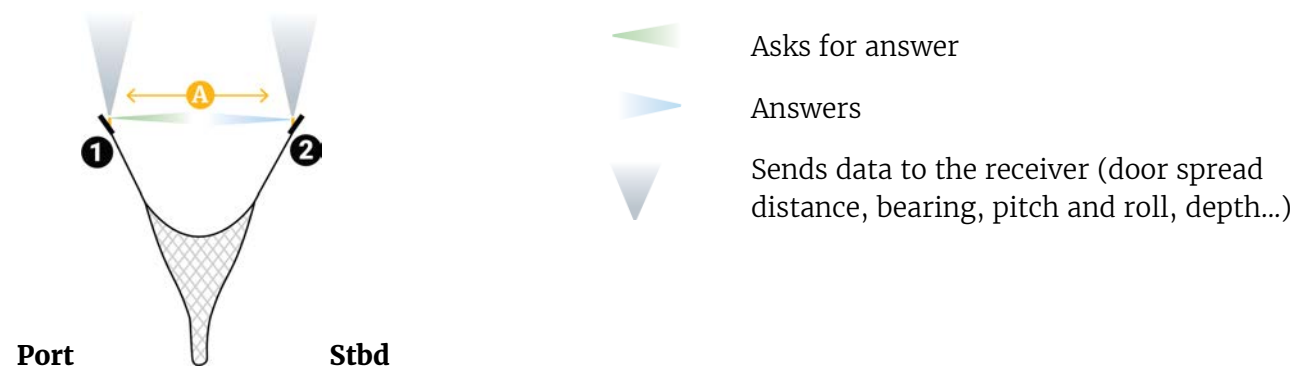

- The port sensor (1) interrogates the starboard sensor (2) to know the distance between them (A). Then, it sends the distance to the receiver.

Twin trawl communication

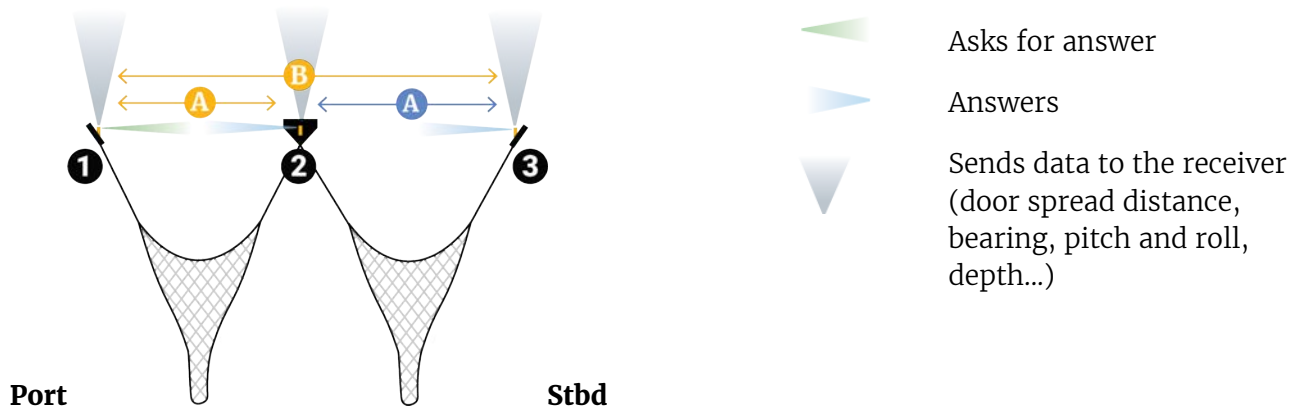

- The port sensor (1) interrogates the clump (2) and starboard sensors (3) to know the distance with each one. Then, it sends the two distances (**yellow A, B**) to the receiver.
- The clump sensor (2) listens to the answer of the starboard sensor. Then, it sends the distance between them (**blue A**) to the receiver.

Triple trawl communication

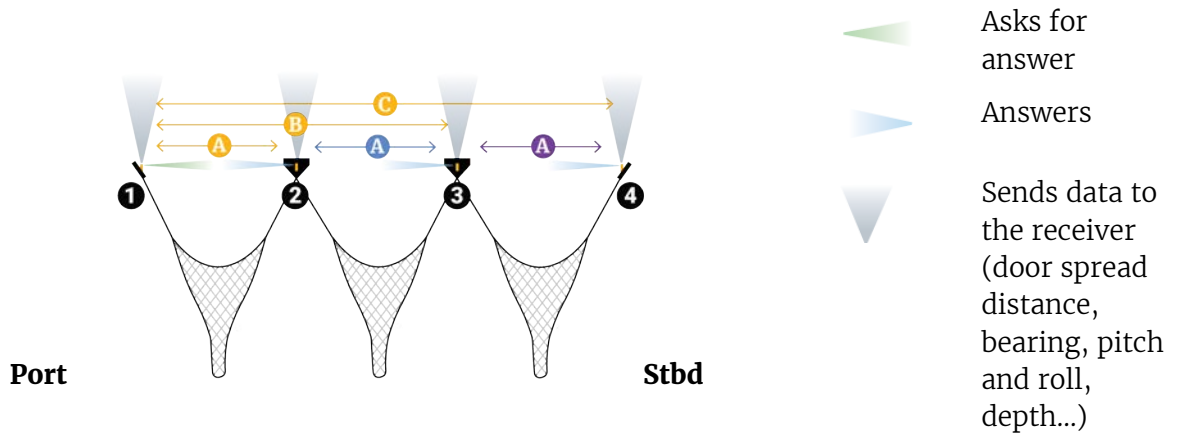

- The port sensor (1) interrogates the port clump sensor (2), the starboard clump sensor (3) and the starboard sensor (4) to know the distance with each one. Then, it sends the three distances (**yellow A, B, C**) to the receiver.
- The port clump sensor (2) listens to the answer of the starboard clump sensor. Then, it sends the distance between them (**blue A**) to the receiver.
- The starboard clump sensor (3) listens to the answer of the starboard sensor. Then, it sends the distance between them (**purple A**) to the receiver.

Quadruple trawl communication

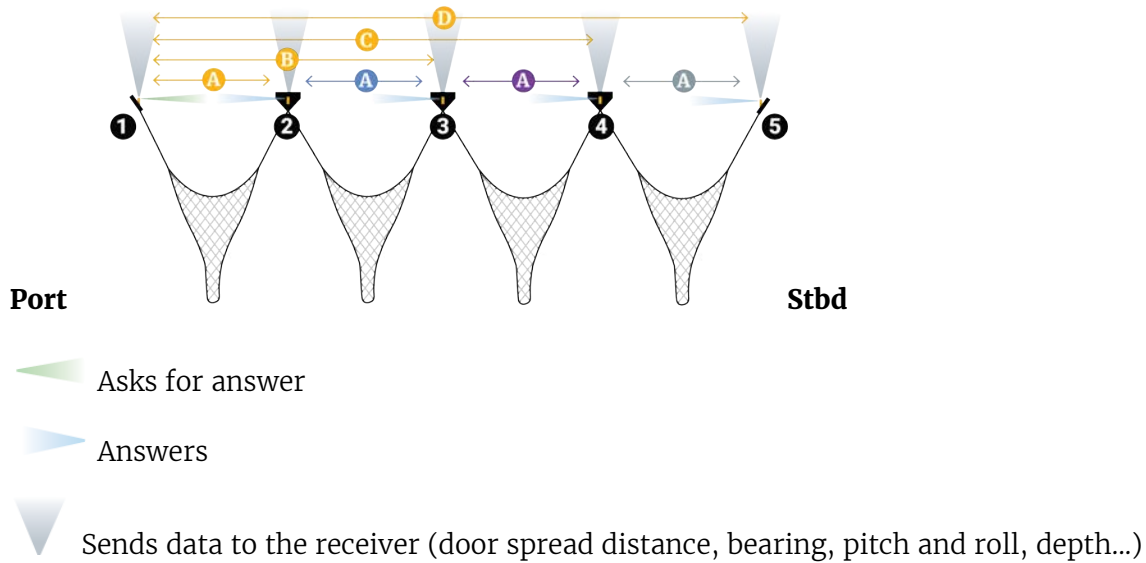

- The port sensor (1) interrogates the port clump sensor (2), the center clump sensor (3), the starboard clump sensor (4) and the starboard sensor (5) to know the distance with each one. Then, it sends the four distances (**yellow A, B, C, D**) to the receiver.
- The port clump sensor (2) listens to the answer of the center clump sensor (3). Then, it sends the distance between them (**blue A**) to the receiver.
- The center clump sensor (3) listens to the answer of the starboard clump sensor (4). Then, it sends the distance between them (**purple A**) to the receiver.
- The starboard clump sensor (4) listens to the answer of the starboard sensor (5). Then, it sends the distance between them (**gray A**) to the receiver.

About Trawl Positioning

This topic explains how the position of the trawl is calculated.

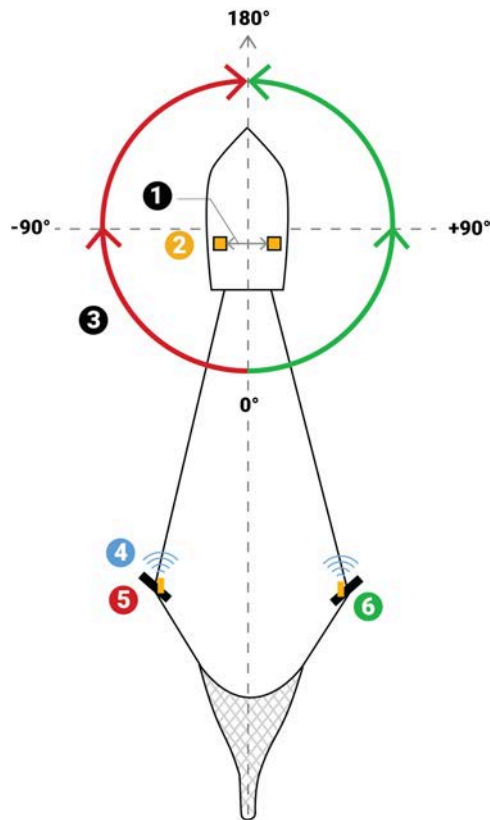

Angles are relative to the stern of the vessel. Angles toward port side are negative and angles toward starboard side are positive.

The distance is calculated from the warp lengths sent by a winch control system. Scala2 application can calculate the positioning of the trawl from this distance, the depth and bearing angle.

The distance between the two hydrophones (2) is called the baseline (1).

To have positioning data, the system must have the following equipment:

- 2 receiving hydrophones:
 - 2 passive hydrophones + wideband preamplifier (ref NC-2-02)
 - OR 2 active wideband hydrophones (ref. NC-1-08)
- Warp lengths
- Baseline calculation
- GPS and heading input

! Important: The two receiving hydrophones must have a minimum distance of **1 meter** between each other.

! Important: You need to remove the 50kHz notch filter on the wideband preamplifiers.

! Important: On **M4 and M6 systems**, the receiving hydrophones must be both connected to a hydrophone input between H1, H2 and H3 or both between H4, H5 and H6. The transmitting hydrophone must be connected to a different set of hydrophone inputs than the receiving hydrophones (for example, if the receiving hydrophones are connected to H1 and H2, the

transmitting hydrophone must be connected to a hydrophone input between H4, H5 and H6).

Description

System Compatibility

The PRP Spread sensors are compatible with the following versions of receiver firmware, Scala, Scala2 and Mosa2.

Protocol	Receiver firmware	Scala/Scala2	Mosa2
PRP	<ul style="list-style-type: none"> • Single and twin trawl: • M3/M5/M6: 05.01.x or later • M4: 04.02.28 or later • Triple and quad trawl: 07.00.x or later 	<ul style="list-style-type: none"> • Scala2: 02.00.02 or later • Scala: 01.02.x or later (only single and twin trawls) 	02.03.x or later

Technical Specifications

Uplink frequency	30 to 60 kHz
Range to vessel	up to 2500 m*
PRP Spread sensor data update rate	Spread: 3-15 sec. - Depth: 3-8 sec. - Temp: 3-16 sec. - Pitch, roll: 3-15 sec.
Depth range	up to 1800 m
Depth resolution	0.1 m with 0.1% full scale
Pitch and roll angles	±90°
Pitch & roll accuracy	±0.1°
Temp measurement range	-5° C to +45° C
Temp accuracy	±0.1° C
Typical battery life†	Up to approx. 25 days (approx. 12 days for stubby version) †
Charging time	Standard: 8-12 hours ‡
	Fast Charge: 4 hours
Battery type	Lithium-Ion
Spread Sensor weight in air (with housing)	7.3 kg
Spread Sensor weight in water (with housing)	2.4 kg
Mini Spread Sensor weight in air (with housing)	4 kg, slim 3.3 kg
Mini Spread Sensor weight in water (with housing)	1 kg, slim 0.9 kg
Warranty	2 years (Sensor & Battery) **

*Reference only. Depends on functions enabled. / † Depends on sensor uplink power and options. / ‡ Based on average charging time. / **Marport Standard Marine Limited Warranty

Dimensions

Standard Spread sensors (XL bottle)

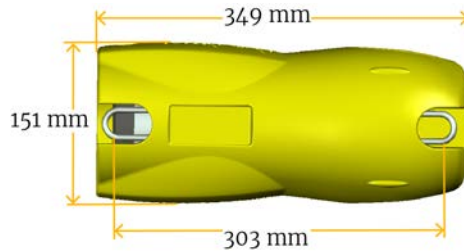

Mini Spread sensors (stubby bottle)



Mini Spread sensors (stubby bottle with slim housing)

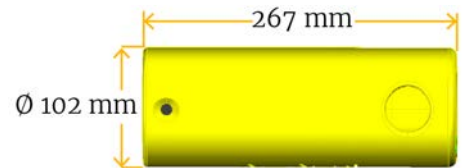

Main Parts

This topic describes the housing and components of the sensor.

PRP Spread Sensor



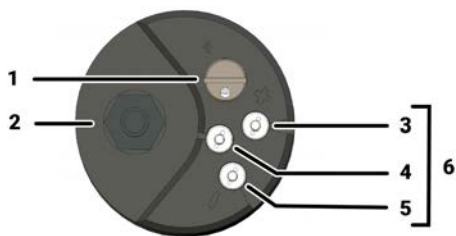

External View

End cap



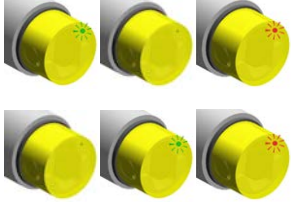
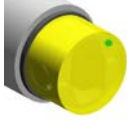

1. Pressure sensor
2. Temperature sensor
3. Positive charge
4. Water switch
5. Negative charge
6. Shoulder bolts

Operational Mode Indicator

State	Situation	LED
Starting	Sensor has just been switched on.	 <p>Start up sequence: LED blinks green/off/red/off/green/red.</p>
Initializing	<ul style="list-style-type: none"> • Start up sequence is complete. • Sensor is in water. • Water switch is on. 	 <p>LED is fixed green for a few seconds.</p>
Running	<ul style="list-style-type: none"> • Initialization phase is complete. • Sensor is in water. • Water switch is on. 	 <ul style="list-style-type: none"> • LED blinks red when a signal is sent by the uplink. • Or, LED blinks green / red if the product configuration is not valid.
Configuring	<ul style="list-style-type: none"> • Sensor is out of water. • User is testing and configuring • Sensor turns off after 10 min. without test or configuration operation. 	 <p>LED blinks green.</p>
Updating firmware	<ul style="list-style-type: none"> • Sensor is in Bootloader mode. 	 <p>LED slowly blinks green.</p>
Charging	<ul style="list-style-type: none"> • Charger plug is connected. • User is configuring at the same time. 	 <p>LED blinks red.</p>

Sensor Configuration

Learn how to configure the sensor settings.

 **Note:** To configure the sensor on Mosa2: Press command + A or click **Menu**  and click **User Mode > Advanced**

Connecting the Sensor to Mosa2

Using a Dock Charger Plug

About this task

 **Tip:** Refer to Dock user manual to have more details about the use of this product.

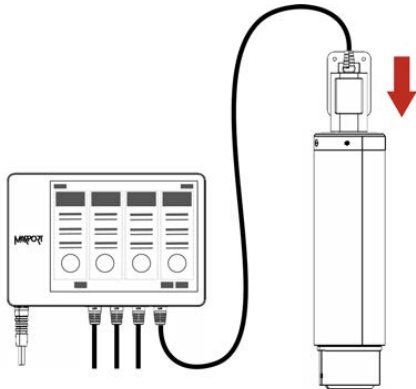

Procedure

1. Connect one Dock charging plug to the sensor's endcap.

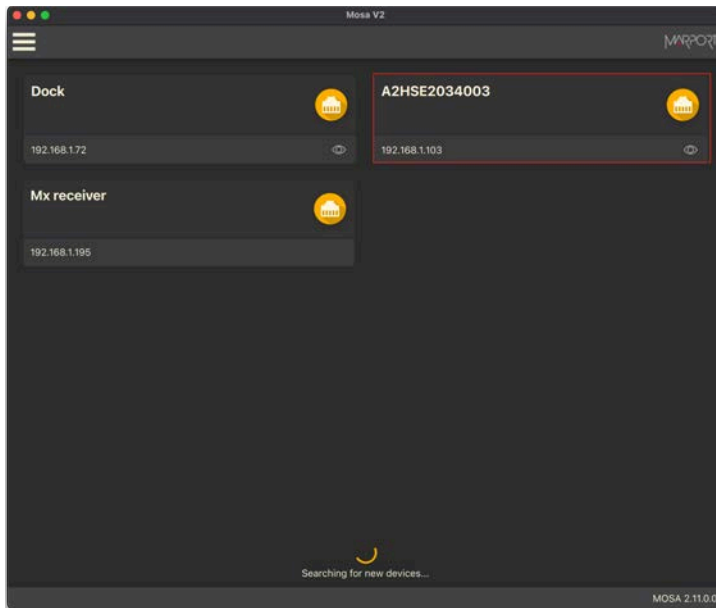

2. Mosa2 discovery page opens. The sensor is displayed.



- Click  to open the sensor configuration page.
- Click  to show the deploy animation on the charger plug for 30 seconds.

Using the Configuration Cable

Simply connect the Configuration Cable from the computer to the sensor to display the sensor configuration page on Mosa2.

About this task

 **Tip:** Refer to the [Configuration Cable Quick Reference Guide](#) for more details about the use of this product.

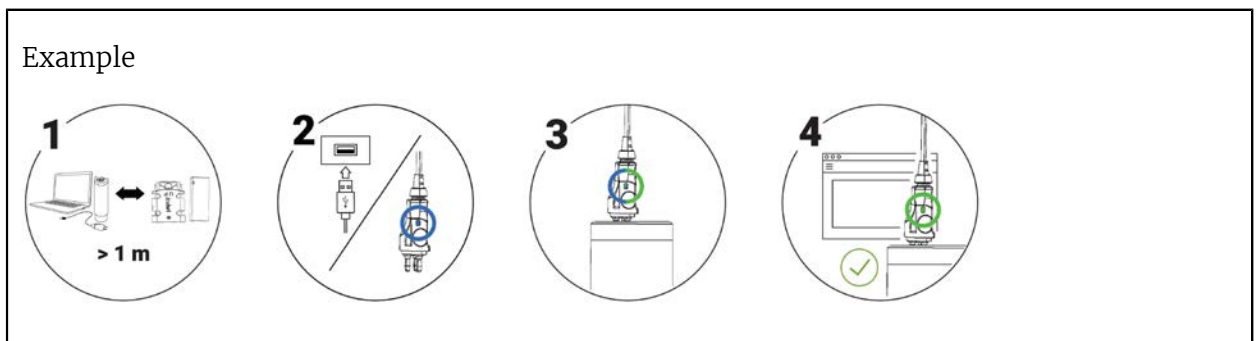

Procedure

1. Move other electrical devices minimum 1 m away from the computer.
2. Connect the USB connector directly to the computer.
Mosa2 opens automatically and the startup wizard is displayed. The LED on the plug is solid blue.
3. Connect the three-pin plug to the sensor.
The LED on the plug blinks alternatively blue and green.
4. Wait a few seconds. The configuration page of the sensor is displayed on Mosa2.
The LED on the plug is solid green.



What to do next

You can now configure the sensor.

 **Note:** You can keep the Configuration Cable continuously connected by USB, and virtually eject or connect it. When no sensor is connected to the Configuration Cable, click **Menu**  > **Eject Config Plug** or **Connect Config Plug**. When ejected, you come back to the discovery page. It stays disconnected until you virtually connect to it or manually disconnect then connect it.

Battery Information

The battery lifetime is displayed on the first page.

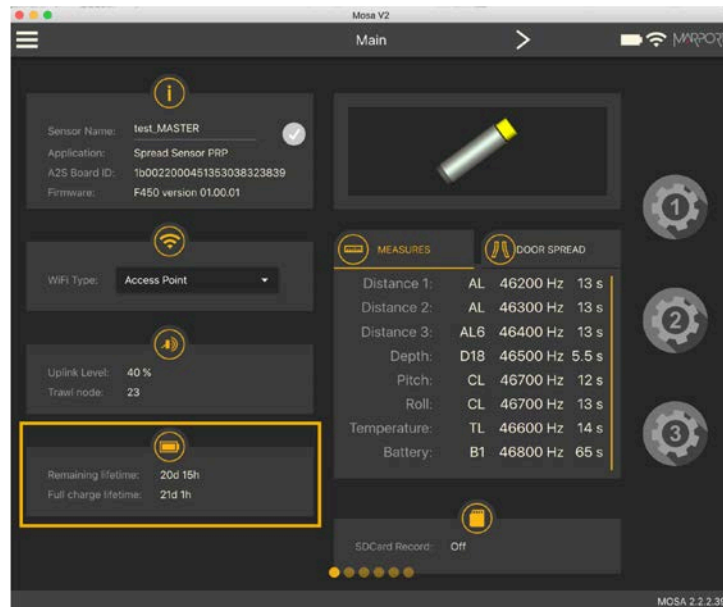

You can also check the battery level at anytime from the top bar:

 **Note:** When you change settings such as the uplink power or sounding range, it affects the battery level and remaining lifetime. The battery information will update after the sensor has been switched on and operating for 10 minutes.

Configuring Door Spread Settings

Configure the communication settings between the spread sensors.

Procedure

1. Go to the **Door Spread** page, then click  in **Door Spread**.

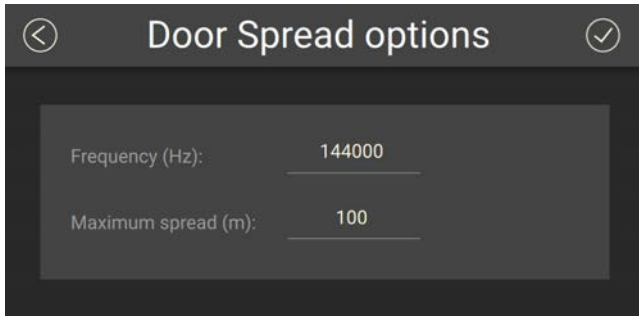

2. Enter a frequency for the communication between all spread sensors.

 **Note:** The frequency must be the same for all of them.

3. Enter the maximum spread between:

- Master sensor placed on the port door: distance to the starboard door.
- Starboard sensors placed on the clumps: distance to closest clump, toward port direction.

 **Note:** You can set a spread distance between 50 and 800 meters. A lower maximum spread distance will save battery life. We recommend to put a value a little higher than the estimated distance to keep a safe margin.

Configuring the Trawl Node

You need to give a trawl node to the sensor. It is the number corresponding to the position of the sensor on the trawl.

Procedure

1. Go to the **Communication** page, then click  in **Uplink**.
2. Enter a node according to the position of the sensor on the trawl.

Sensor location	Trawl gear node
Port	23
Starboard	<ul style="list-style-type: none"> • Single trawl: 26 • Twin trawls: 123 • Triple trawls: 223 • Quadruple trawls: 323
Clump	<ul style="list-style-type: none"> • Twin trawls: 26 • Triple trawls: 26, 123 • Quadruple trawls: 26, 123, 223

 **Important:** Make sure to put the same number when adding the sensor to Scala2 receiver page. If not, change it accordingly.

3. Click .

Configuring the Uplink Frequency and Power

Configure the settings of the communication link between the sensor and the vessel.

Procedure

1. Go to the **Communication** page, then click  in **Uplink**.

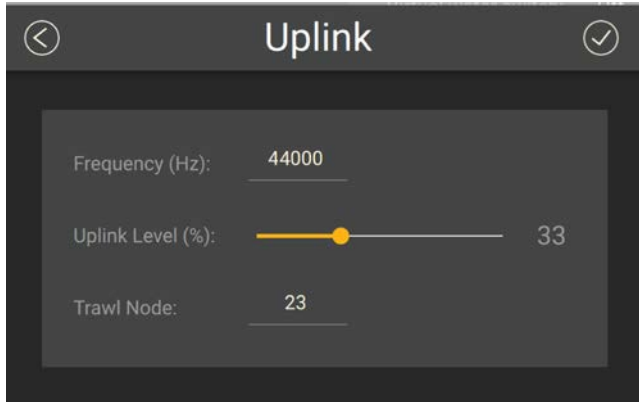

2. Enter a frequency for the communication with the vessel. Default is 44000 Hz.
3. Drag the slider to change the power of the uplink signal.

 **Note:** A higher level of uplink power reduces the battery lifetime.

Recommended Uplink Powers	Conditions	Battery Life
44%	Works for most conditions.	9 to 30 days, depending on settings
100%	<ul style="list-style-type: none"> • Sensor is far from vessel (e.g. more than 800 m depending on conditions, high depth) • High level of interferences • Issues receiving data • Low SNR 	

Configuring PRP Spread Sensors Telegrams

You change the telegram assigned to each type of measurement.

Procedure

1. In **Communication** page, you can see the list of the telegrams sent by the sensor. Click  to see a picture of the trawl with the position of the sensor.

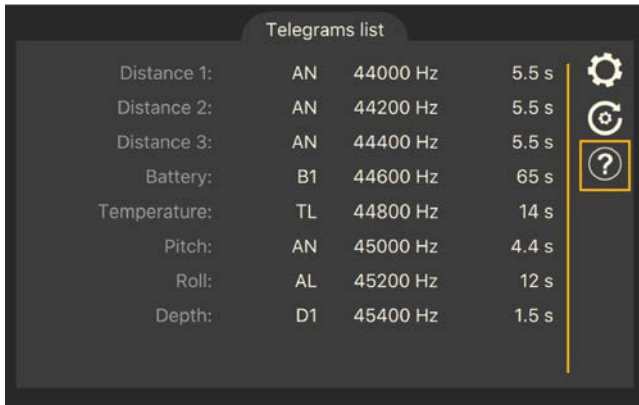

2. Click  in **Telegrams List**, then set a telegram and a frequency for each data.

Option	Telegram	Value and/or update rate
Distance	AL	Less than 250 m, every 11 to 15 sec.
	AN	Less than 250 m, every 3 to 8 sec.
	AL6	Less than 610 m, every 11 to 14 sec.
	A6	Less than 610 m, every 3 to 8 sec.
Depth	D3	300 m, every 3 to 8 sec.
	D6	600 m, every 3 to 8 sec.
	D12	1,200 m, every 3 to 8 sec.
Temperature	TL	Every 11 to 16 sec.
	TN	Every 3 to 11 sec.
Pitch and Roll	CL	Every 11 to 14 sec.
	VQ	Every 5 to 9 sec.
Pitch	D6	Every 3 to 4 sec.
	AN	Every 3 to 6 sec.
Roll	D3	Every 3 to 8 sec.
	AL	Every 11 to 15 sec.
Battery	B1	Every 60 to 70 sec.

 **Note:** Using telegrams that send data more often reduces the battery life.

3. Click  and drag it to change the order in which data are sent.

On/Off	Data	Telegram	Uplink frequency	Priority
<input checked="" type="checkbox"/>	Distance 3	AL6	46400 Hz	☰
<input checked="" type="checkbox"/>	Distance 2	AL	46300 Hz	☰
<input checked="" type="checkbox"/>	Distance 1	AL	46200 Hz	☰
<input checked="" type="checkbox"/>	Pitch	CL	46700 Hz	☰
<input checked="" type="checkbox"/>	Temperature	TL	46600 Hz	☰
<input checked="" type="checkbox"/>	Depth	D18	46500 Hz	☰
<input checked="" type="checkbox"/>	Battery	B1	46800 Hz	☰
<input type="checkbox"/>	Roll	CL	46700 Hz	☰

Configuring Positioning Signal Settings

Configure the following settings if the sensor has the positioning option.

Procedure

1. Go to **Positioning** page and click  in **Chirp**.

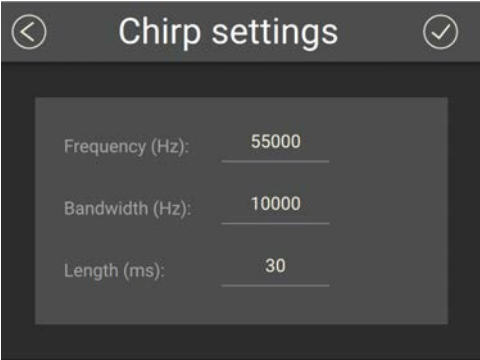
2. 

- a) Enter the central frequency of the signal sent by the sensor.
- b) Enter the frequency bandwidth. We do not recommend to enter a bandwidth lower than 10000.
For example, if the center frequency is 50000 Hz and the bandwidth is 10000 Hz, the signal will cover the frequency from 45000 Hz to 55000 Hz.
- c) Enter the chirp length, recommended value is 30 ms.

Calibrating the Pitch and Roll

You need to calibrate the pitch and roll of the sensors when placed on the trawl doors.

Before you begin

-  **Tip:** Some trawl door manufacturers measure the pitch and roll offsets themselves and write them on the doors. Check on trawl doors.

About this task

A sensor pocket is usually welded to the door at a 15 to 20 degree vertical angle. This means that when trawl doors are vertical, the sensors will already have a pitch angle and maybe a roll angle. You need to calculate these angles and offset them in order to have 0° of pitch and roll when doors are vertical.

Calibrating Automatically

Procedure

1. Remove all rigging, shackles and attachment points from the doors.
2. Remove the net gear attached to the door.
3. Using a crane or forklift, place the door on a flat surface, such as a dock or similar location.
4. Using the necessary rigging, hang doors with angles as close to 0 degree as possible on the vertical and horizontal plane. Use a carpenter level to help you.
5. Insert the sensor in the pockets on the doors.



6. From Mosa2, go to **Measurements** page and click  in **Motion**.
7. Check on the bottom of the window that the pitch and roll of the door are close to 0 degree.
8. From **Opening Angle**, enter the angle between the door and the sensor (horizontal plane) in degrees. If you do not know the angle, ask the manufacturer for the angle of attack. If you cannot know the angle, you can put 35° but be aware that a wrong angle impacts pitch and roll measurements.
9. Click **Calibrate**.

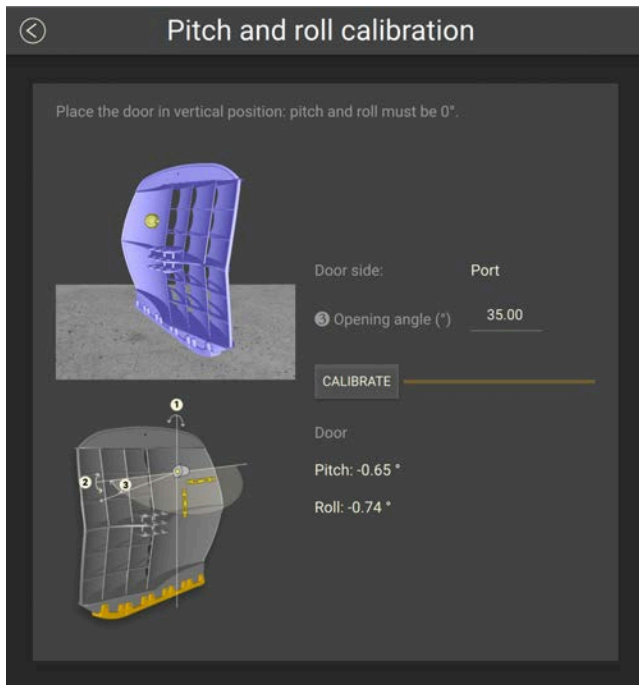



The sensor is calibrated.

Applying Offsets to Measurements

You can apply offsets to temperature and depth measurements if the measured values does not correspond to the environment of the sensor.

Procedure

1. Press command + A or click **Menu**  and click **User Mode > Advanced**.
2. Go to **Measurements** page and click  next to depth or temperature to apply offsets.
3. Enter a target value. Click .

The measured value becomes the same as the target value. The value of the offset is displayed.

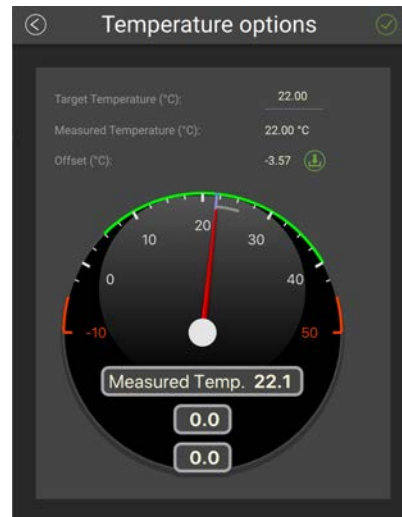
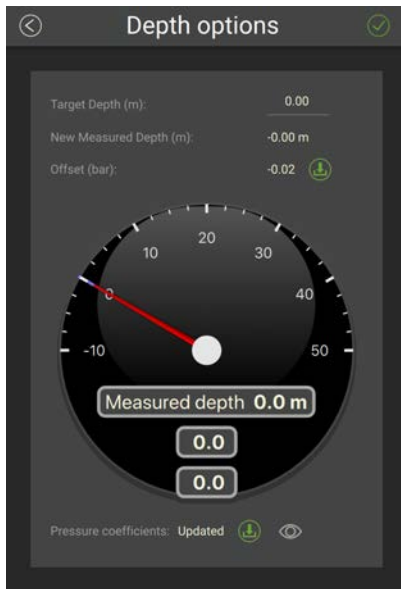

4. If you need to reuse offsets from a previous configuration, click  then select the configuration file (*.A2C).

Testing Measures

You can test the measures taken by the sensor (e.g. battery level, temperature, depth) to check that there are no faults.

About this task

You can test the sensor in water or in air. In air, the following measures will be wrong: height, conductivity.

Procedure

1. Press command + A or click **Menu**  and click **User Mode > Advanced**
2. Go to the **Monitoring** page.

You can check information about the battery, board and sensor.



3. Go to the **Measurements** page.

You can see the values of the activated measures, such as depth, temperature. If the sensor is working correctly, measures are updating.

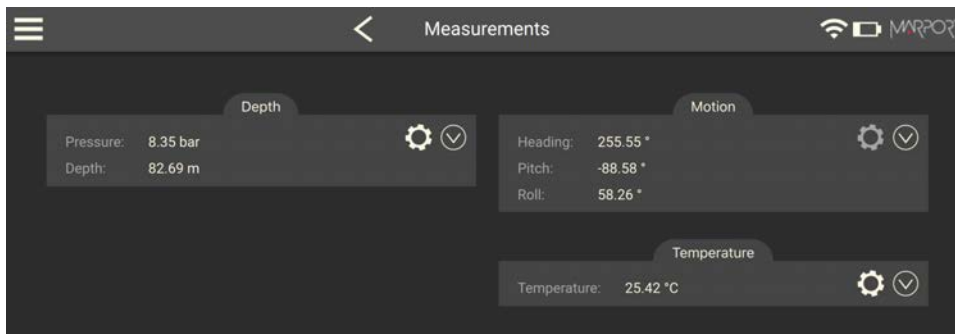

4. Click  to check and, if necessary, adjust data measured by the sensor:

- **Depth:** Place your sensor on a desk or on the ground and enter 0 in **Target Depth**.
- **Temperature:** Enter the estimated temperature of your environment.
- **Motion:** Calibrate the door sensors.

Saving a Configuration on Mosa2

You can save different configurations of the sensor to be able to quickly change the configuration when you change your fishing method.

Before you begin

- You have finished configuring the sensor.

About this task

You can have up to three different configurations for the sensor. When you change your fishing method, you can apply a corresponding configuration in one click. For example:

- If fishing in shallow water, you can use a configuration with an uplink level of 20%, a short pulse and a short range.
- If fishing in greater depths, you can change for a configuration with an uplink level of 60%, a long pulse and a long range.

Procedure

1. When you are finished configuring the sensor, for example to use the sensor in shallow water, click one of the wheel icon  on the first page of Mosa2.
2. In the window that appears, enter a name for the configuration and save it. The wheel icon becomes orange and the name of the configuration is displayed underneath.

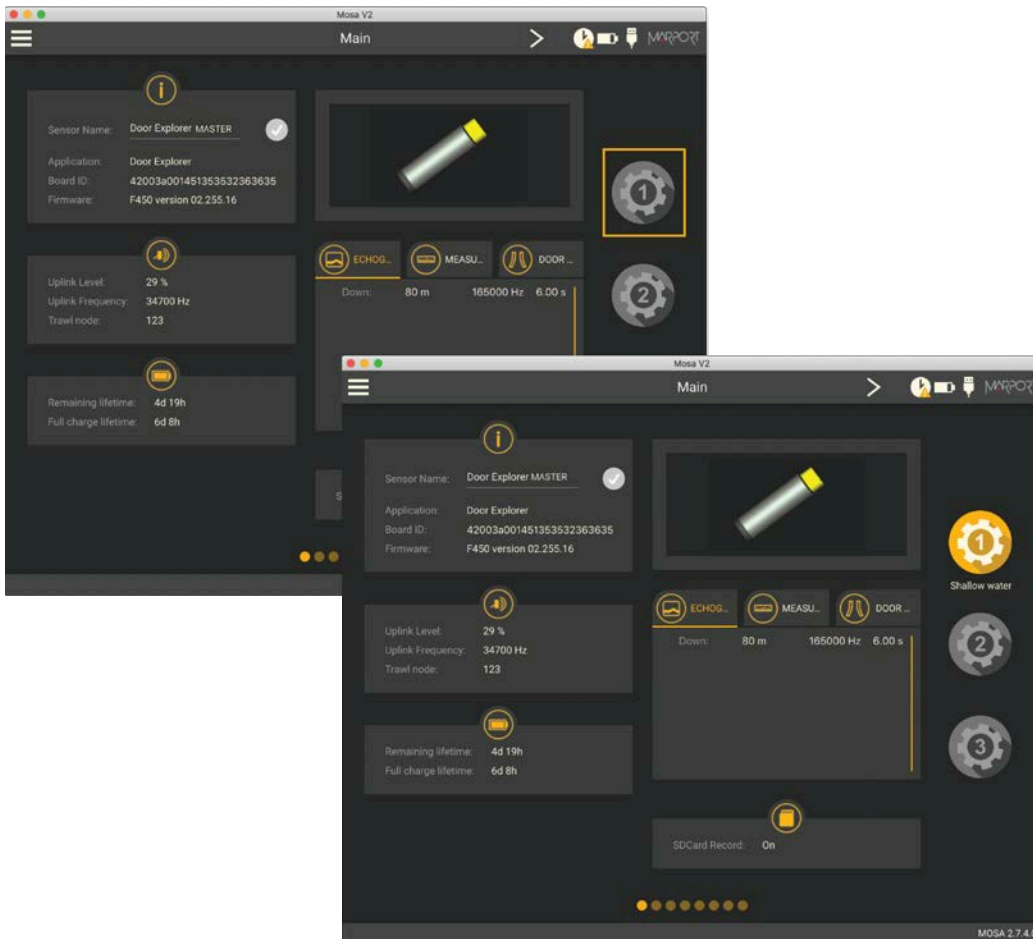

3. To create another configuration, for example this time to use the sensor in deep waters, change the settings of the sensor on Mosa2.
4. When you are finished, click the second wheel icon and save the configuration.
5. If you need to change the sensor configuration back to the first configuration (shallow water), click the corresponding wheel. The configuration is applied.
6. If you need to make changes to a configuration:
 - a) Change settings.

- b) Maintain the click on the corresponding wheel until the **Manage Configuration** window appears.
 - c) Click **OK** in **Save Current Configuration**.
7. To delete a configuration:
- a) Maintain the click on the corresponding wheel until the **Manage Configuration** window appears.
 - b) Click **OK** in **Delete Saved Configuration**.

Exporting Sensor Configuration

You can export the sensor settings you configured on Mosa2 on a file. You can afterward use this file when configuring a similar sensor.

Before you begin

- You are finished configuring the sensor.

About this task

If you have issues with your sensor, send this file to support teams.

Procedure

1. Click **Menu**  > **Export**.

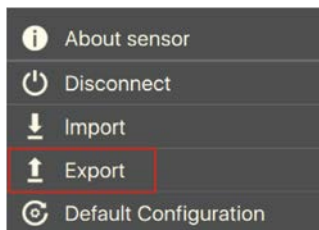

2. From the window that appears, choose a folder on your computer to save the file and click **Open**.

Results

The configuration file is exported and saved on your computer as an A2C file. If you are connected to the internet, it is also automatically sent to MASP in XML and PDF files:

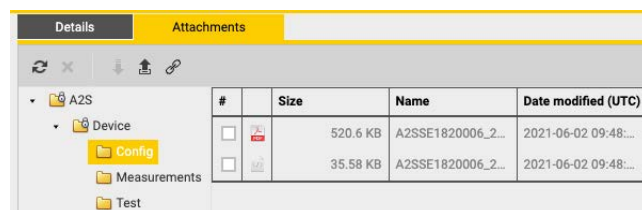

#	Size	Name	Date modified (UTC)
<input type="checkbox"/>	520.6 KB	A2SSE1820006_2...	2021-06-02 09:48...
<input type="checkbox"/>	35.58 KB	A2SSE1820006_2...	2021-06-02 09:48...

Importing a Sensor Configuration

You can apply to a sensor a configuration that has already been made on another sensor.

Before you begin

- You have exported a configuration (see [Exporting Sensor Configuration](#) on page 29) and have the *.A2C or XML configuration file.

About this task

Only the following settings are imported: trawl node, recording settings (SD card, support logs), communication options (virtual water switch, simulation mode), uplink level and frequency, echo sounder settings.

! Important: If the new configuration change the echo sounder settings, you must re-calibrate the sensor for target strength value.

Procedure

1. Press command + A or click **Menu** ☰ and click **User Mode > Advanced**
2. Click **Menu** ☰ > **Import**.

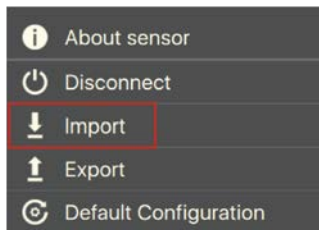

3. From the window that appears, select the *.A2C or XML configuration file.

Results

The configuration is loaded into the sensor.

System Configuration and Display

Learn how to configure the receiver and display the sensor data in Scala2 application.

Adding the Sensors to the Receiver

You need to add the sensors to the receiver in order to display their data on Scala2.

For compatibility details, see [System Compatibility](#) on page 14.

Adding the Sensors to the Receiver

You need to add the sensors to the receiver using the system web page.

Procedure

1. From Scala2, click **Menu**  > **Expert Mode** and enter the password `copernic`.
2. Right-click the IP address of the receiver at the bottom of the page, then click **Configure Receiver**.
3. From the left side of the receiver page, click **Sensors**.
4. From the page **Add Sensor Product** select the options according to your type of sensor:

Product Category	Product Name	Trawl Gear Location
Spread Master	Spread Master + options*	23
Spread Starboard	Spread Starboard + options*	<ul style="list-style-type: none"> • Single trawl: 26 • Twin trawls: 123 • Triple trawls: 223 • Quadruple trawls: 323
Spread Clump	Spread Clump + options*	<ul style="list-style-type: none"> • Twin trawls: 26 • Triple trawls: 26, 123 • Quadruple trawls: 26, 123, 223

*The options depend on the firmware installed, e.g. pitch, roll, depth, temperature, battery, bearing.

Configuring Sensor Settings

You need to complete communication settings when you add the sensor to the receiver.

 **Important:** Make sure the settings you enter here are the same as in Mosa2.

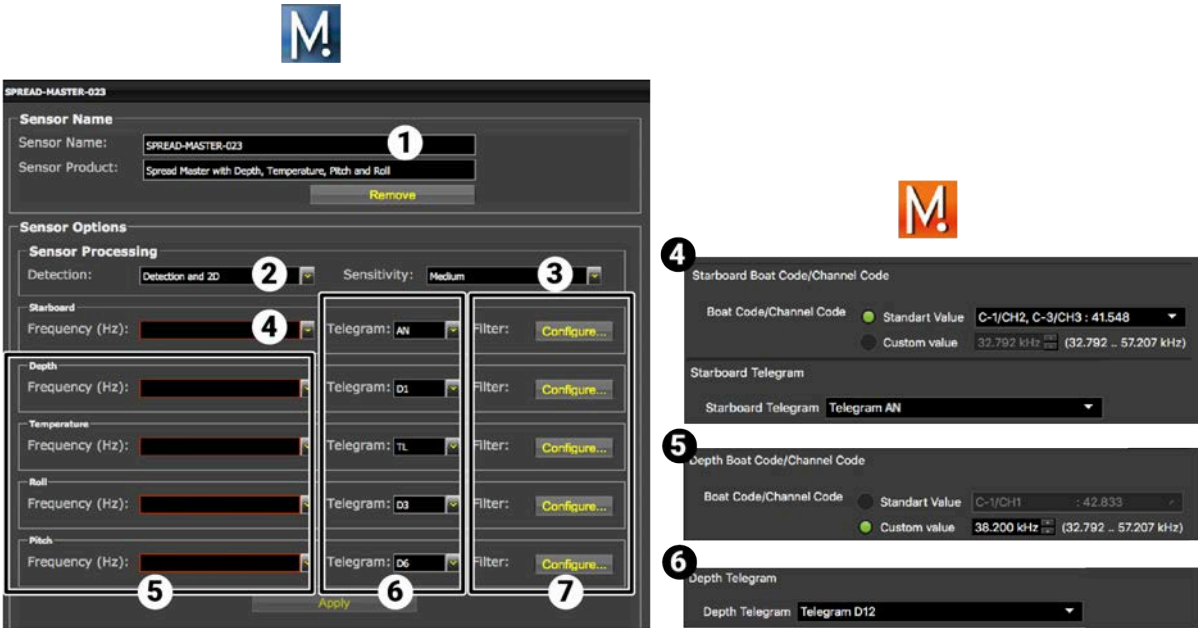

1	Sensor name displayed in Scala2 and its features.
2	This setting helps detecting the signal of the sensor among other sensor or echosounder signals. Change only if you have issues receiving data. <ul style="list-style-type: none"> • Detection and 2D: default value. This setting helps distinguishing the sensor signals when there are a lot of interferences (e.g. echosounders). It selects the correct signals according to very selective criteria. • Detection: If you do not receive data, it may be because the Detection and 2D setting is too selective with the signal. Detection is less selective and allows more signals to be received. • Detection for Seiner: no need for this sensor
3	<ul style="list-style-type: none"> • Low: if the signal of the sensor is high = the trawl is close to the vessel (SNR min. 18 dB). • Medium: Default setting. Compromise between the two other settings (SNR min. 12 dB). • High: if the signal of the sensor is low = the trawl is far from the vessel (SNR min. 6 dB).
4	Master and clump sensors only: enter the same frequencies as those entered in Mosa2 in Clump and Starboard Boat Code/Channel Codes .
5	For each option, enter the same frequencies as those entered in Mosa2 in Boat Code/Channel Codes .
6	For each option, enter the same telegrams as those entered in Mosa2.
7	Click Configure to change filters applied on incoming data.

Click **Apply** when you have finished.

What to do next

Configure the positioning settings if the sensor has the positioning option.

Configuring the System with the Positioning Option

If the sensors have the positioning option, you need to configure the system in order to receive the trawl position and display it in Scala2.

Configuring the Positioning Settings

Configure the positioning settings on the system web page to correctly receive the positioning data from the sensors.

Before you begin

You have added the sensors to the receiver.

i Tip: A spreadsheet is available on Marport support website to help you complete this page: go to the [Useful Resources](#) page.

Procedure

1. From the left side of the screen where the system is displayed, click **Positioning**.

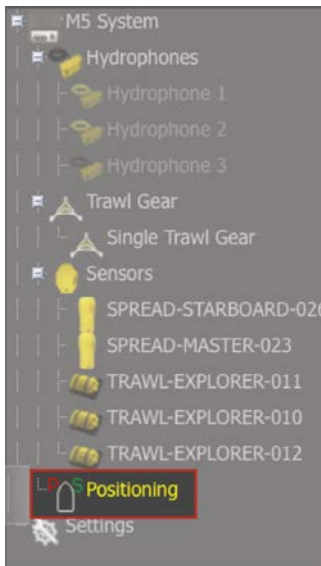

The positioning configuration page appears.

2. In **Baseline**, enter the baseline distance and the misalignment angle.

i Note: The baseline is very important to have accurate positions of the doors.

! Important: If the starboard hydrophone is placed further aft, add a negative (-) sign before the angle.

3. In **Inputs**, enter the port and starboard hydrophones, according to the hydrophone configuration.

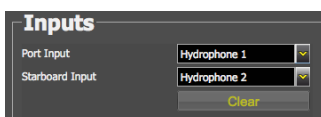

i Note: On **M4 and M6 systems**, the receiving hydrophones must be both connected to a hydrophone input between H1, H2 and H3 or both between H4, H5 and H6.

4. Click **Apply**.

Results

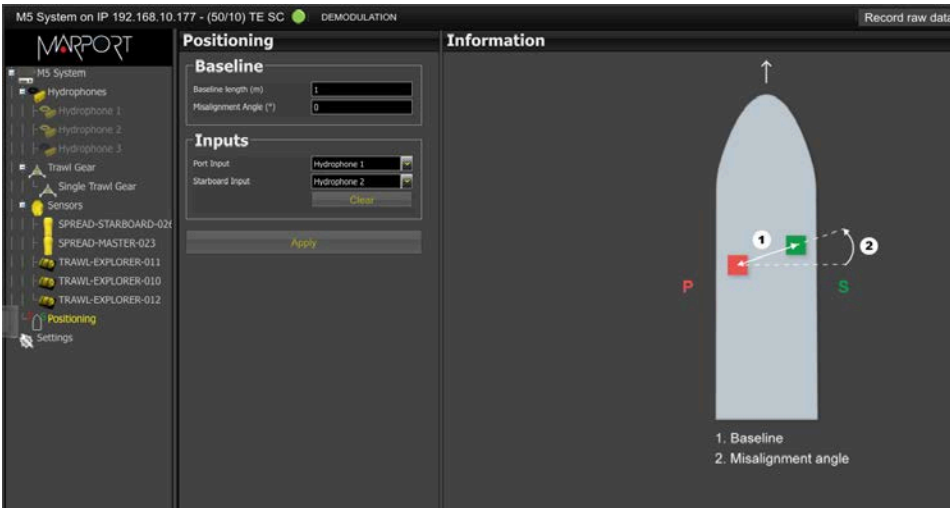

Calculations for the Positioning System

When configuring the positioning system on the system web page (Scala2 receiver page), you must consider the position of the hydrophones. When they are misaligned, you can calculate their misalignment angle with the following calculations.

i Tip: A spreadsheet is available on Marport support website to help you complete this page: go to the [Useful Resources](#) page.

🔧 Note: Baseline length is the distance between two hydrophones. It must be in meters.

The misalignment angle (angular offset around Z axis) is calculated with the following formula:

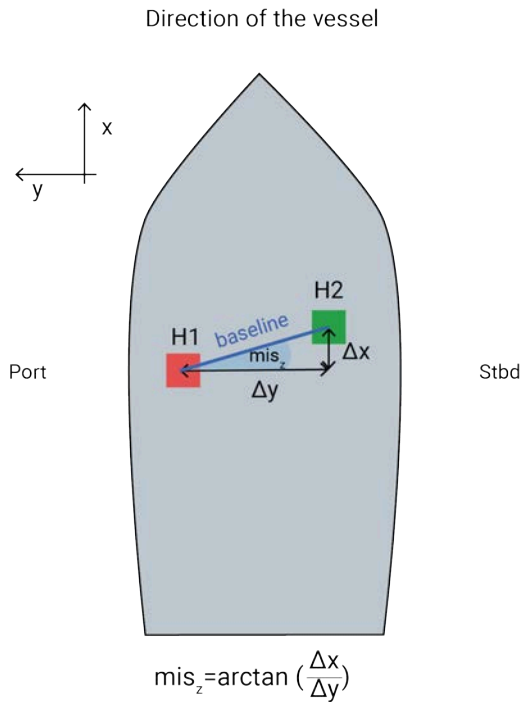

Sign of Angles

You need to add a negative sign (-) to the result if the starboard hydrophone is placed further aft. The sign of the angles is important to receive correct positioning data.

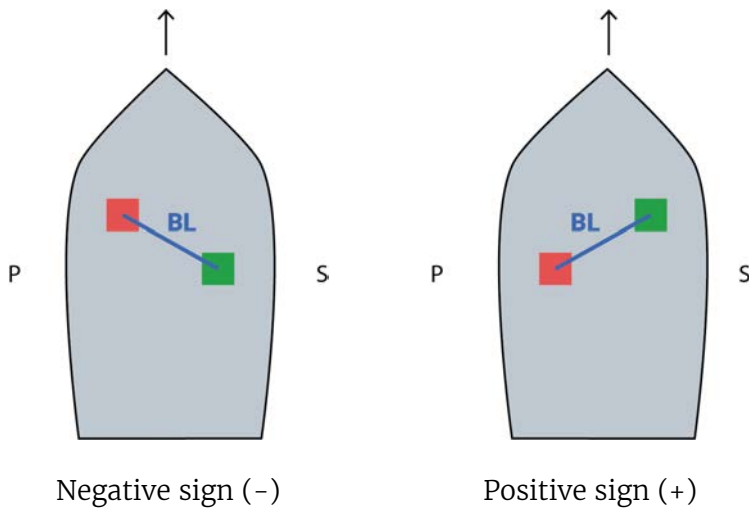

Configuring Trawl Settings

You need to configure trawl settings to display the trawl on the chart and vessel 3D overview.

Procedure

1. Click **Menu** \equiv > **Settings**.
2. From the tab **Trawl**, complete **Headline (H)**, **Bridle (B)** and **Sweepline (S)** with accurate measurements of your trawl gear.



Adding Data from External Devices

You need to add to Scala2: warp lengths, GPS coordinates and heading data received from devices such as winch control systems or GPS compass.

About this task

See [Compatible NMEA Sentences from Winch Control Systems, GPS and Compass Devices](#) on page 79 to know which NMEA sentences are compatible.



Note: Heading data is very important to have precise positioning of the trawl.



Note: Make sure you receive data from only one GPS device or the trawl will not be displayed correctly.



Note: Warp lengths can be received from a winch control system, or entered manually in the control panels, under **Manual Estimation**. If no warp lengths, the positioning will be calculated from the bearing, spread distance and depth data sent by the Spread sensors. However, we strongly recommend to receive warp lengths from a winch control system. Without it, the accuracy of the positioning will be reduced.

Procedure

1. In the control panels, click **NMEA Inputs > Add input**.
2. Choose the type of connection between serial port, UDP or TCP socket.
3. If using a serial port:
 - a) In **Port**, select the incoming data you want to add.
 - b) In **Baud**, choose the transmission speed (bit per second).
 - c) Leave the other default parameters if you have no specific requirements.

- d) Select a different input format if you have Marelec or Rapp Marine/Rapp Hydema equipment. Otherwise, select **Standard NMEA format**.
 - e) To broadcast the data received on this serial port to other equipment than Scala2, select **Output to UDP**, then enter a port above 1000 and enter 255.255.255.255 to broadcast to all equipments, or enter a different subnet mask.
4. If using UDP:
 - a) enter the port of the server sending data.
 5. If using TCP:
 - a) Enter the IP address of the server and the port.
 - b) Select a different input format if you have Marelec or Rapp Marine/Rapp Hydema equipment. Otherwise, select **Standard NMEA format**.
 - c) To broadcast the input data to other equipment than Scala2, select **Output to UDP**, then enter a port above 1000 and enter 255.255.255.255 to broadcast to all equipments, or enter a different subnet mask.
 6. Click **OK**.

Results

NMEA data appears in the **NMEA Inputs** control panel and in the **Ownship** panel. LEDs blink green when data is received (it may be steady green if data is received continuously). When communication with the NMEA devices is lost, LEDs do not blink anymore.

 **Trouble:** If you see a warning sign in front of data it means that you receive the same data from more than one device. Right-click the data, then click **Configure Data** and select the primary source.

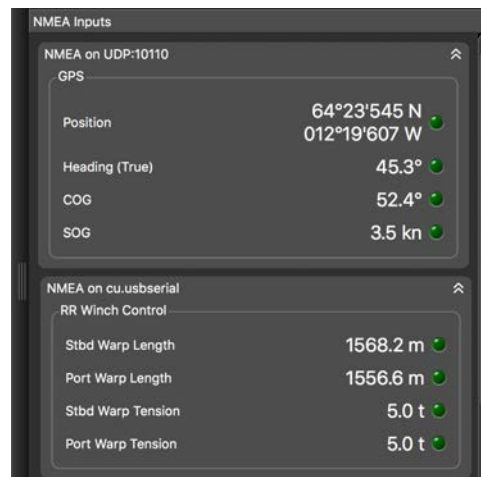
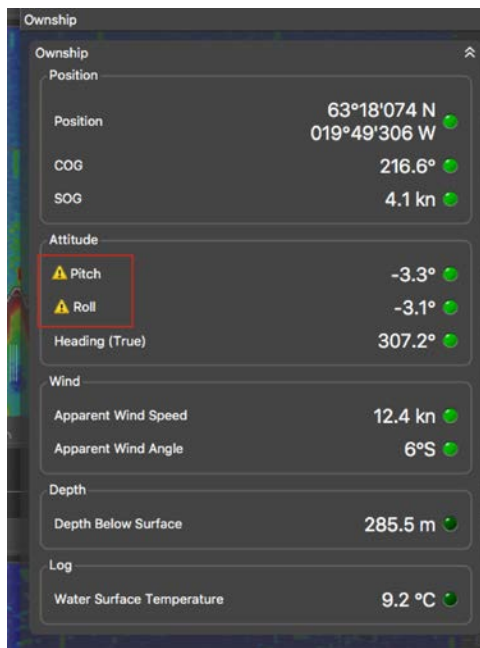

LEDs blink green when data is received (it may be steady green if data are received continuously).
When communication with the NMEA devices is lost, LEDs do not blink anymore.

Receiving Warp Lengths from Scantrol

You can output warp length data from Scantrol iSYM Trawl Control application to Scala2 software.

About this task

 **Note:** In this procedure, data are transmitted via a UDP port but a connection via a serial port can be possible.

Procedure

1. Scantrol and Marport computers must be connected together via an Ethernet wired network. Both computers must be on the same sub-network to communicate with each other: 192.168.0.XX.
For example, the network IP address can be set at **192.168.0.10** on Scantrol computer and at **192.168.0.12** on Marport computer. The subnet mask address is 255.255.255.0 for both.
2. Go to iSYM's **Configure Communication Ports** menu, then in **13: NMEA UDP 1** enter a port number, such as 9000, and set **SEND** to 1.

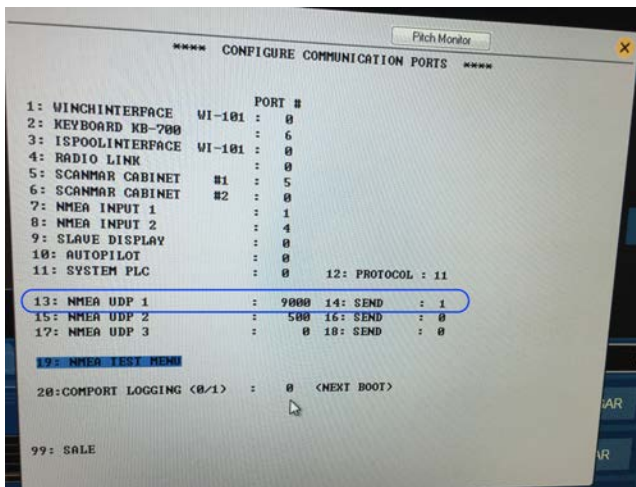

 **Note:** The port number must be different from the one on which Scala2 sends data (if applicable).

3. In Scala2, open the control panels then click **NMEA Inputs > Add input**.
4. Set a UDP connection and enter the corresponding port.

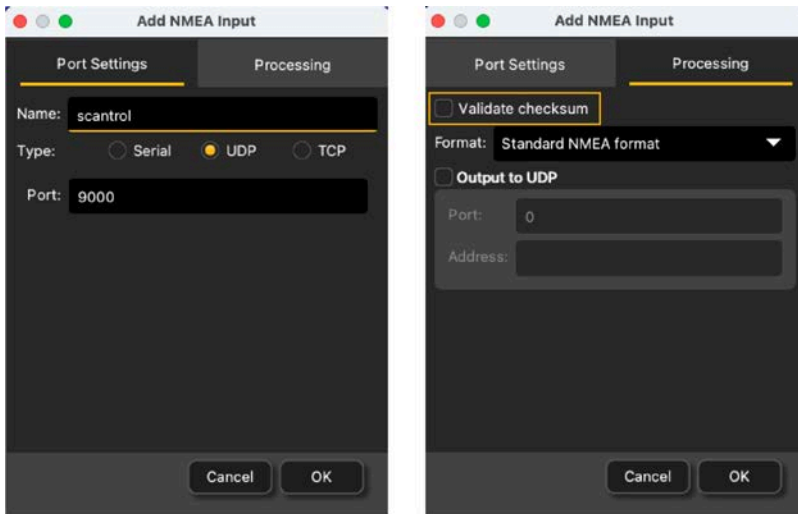

5. Clear the **Validate Checksum** checkbox.

! Important: If you do not clear this checkbox, you will not receive the data from Scantrol.

Results

Scantrol data are displayed in Scala2.

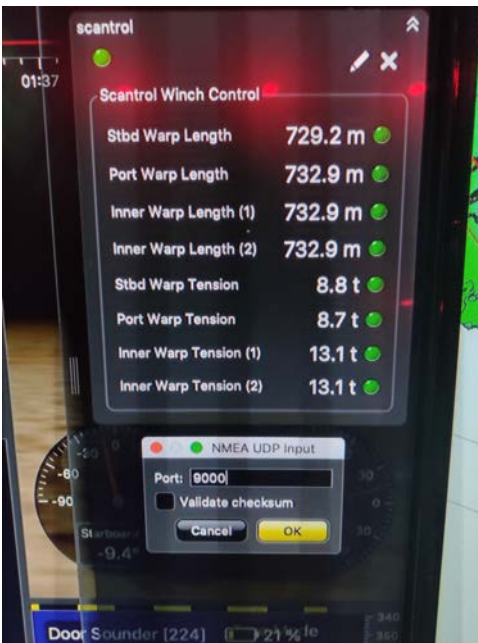

Configuring Data Display on Scala2

Connect in **Customize** mode to configure the display of data. From the top left corner of the page click **Menu** ≡ > **Customize** and enter the password eureka.

Displaying Trawl Door 3D View

You can display a 3D view of the trawl doors and clump. This way, you can see the movements of the doors and clump.

Procedure

1. Open the customization panel and go to the **Mx** panel. Click + drag the **Door 3D View** to the page and select the fishing gear element. If you have twin trawls you can display the clump and if you have twin outrigger trawls you can set which doors are displayed. Repeat for all fishing gear elements.

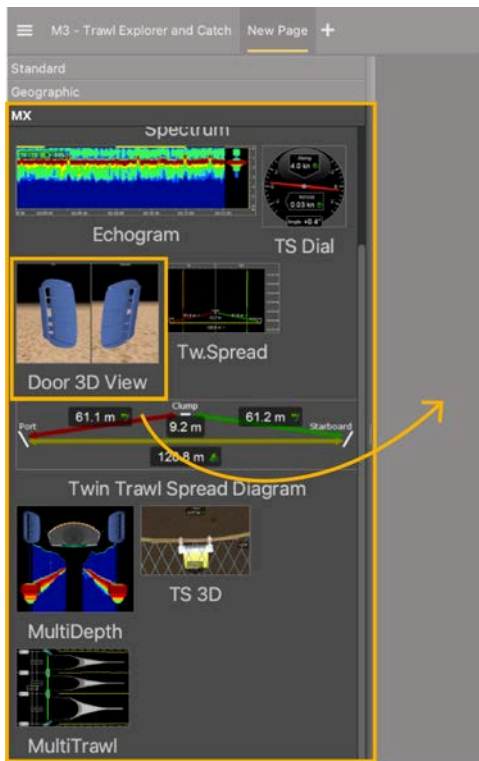

The 3D view is displayed:

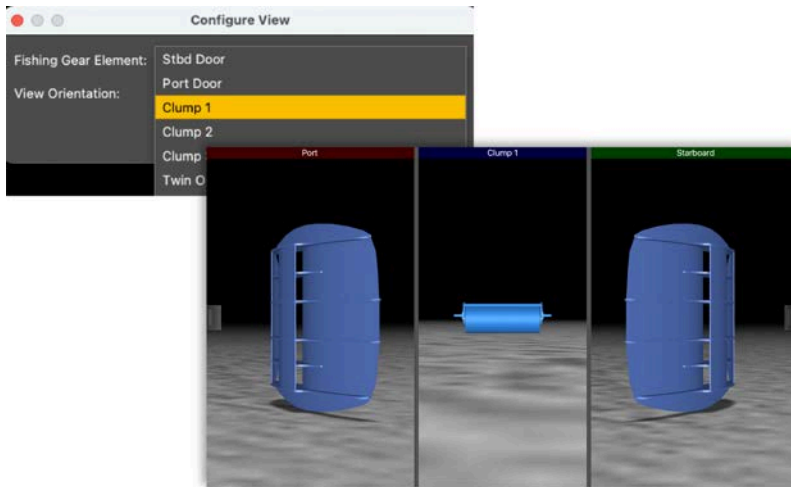

i Tip: You can change the fishing gear element anytime: right-click the 3D view and click **Configure**.

2. You can also change the viewing angle: looking from the trawl toward the vessel (front), or from the vessel toward the trawl (back).

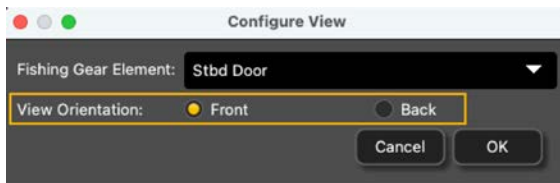

3. To change the door or clump model:
 - a) From the top left corner, click **Menu** ≡ > **Settings**.
 - b) Click the **Trawl** tab and select the models of doors and clump from the lists, using left and right arrows.

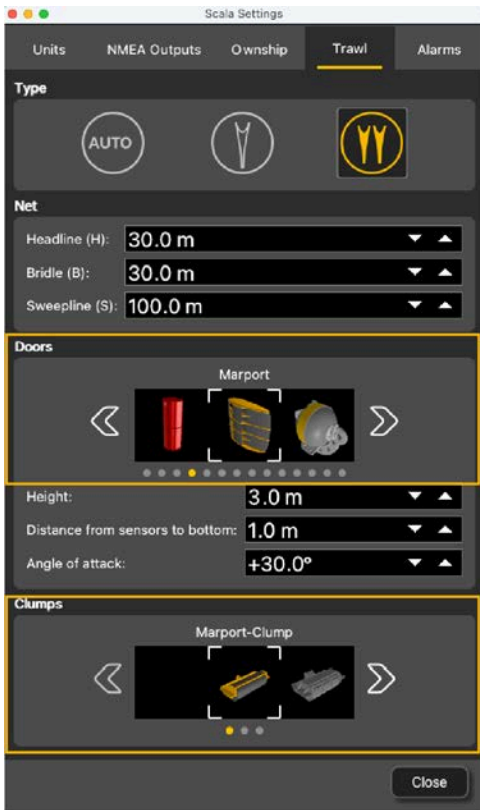

4. To change the view angle of the door, right-click the 3D view and choose:
 - **Horizontal Camera** to see the doors from the front:

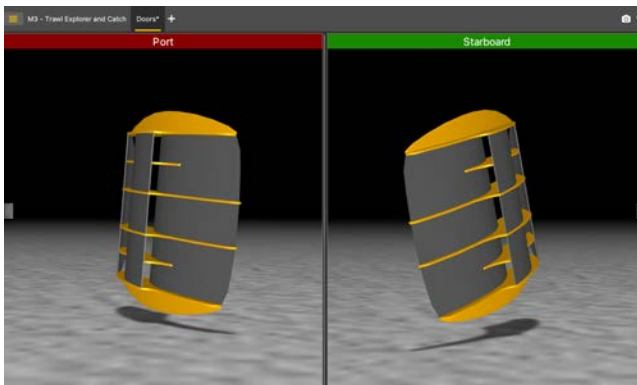

Or back:

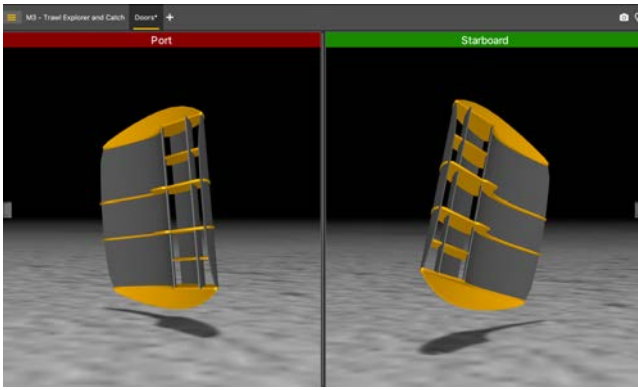

- **Vertical Camera** to see the doors from above.

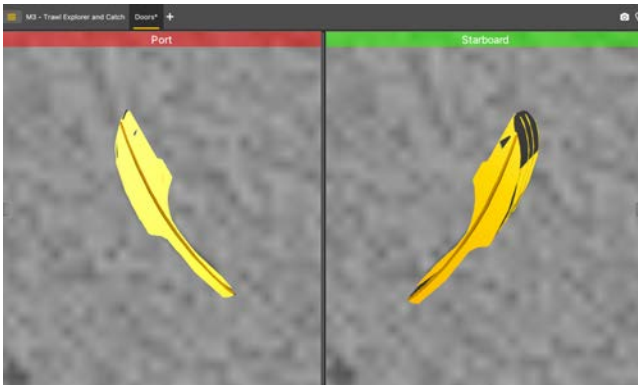

- **Free Camera** to adjust the viewing angle yourself, by clicking and dragging the 3D doors.

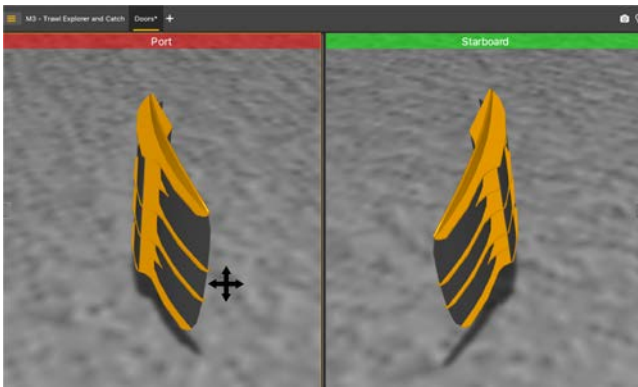

5. To display or hide the ground, right-click the 3D view and select or not **Display Ground**. You should leave the ground displayed, in order to see if the doors are touching it.

Displaying Data from Multiple Trawls

About this task

This topic shows an example of page display for a triple trawl. This can also be applied for twin or quad trawls.

Procedure

1. From the top left corner of the page click **Menu** ≡ > **Customize** and enter the password eureka.

- Open the customize panel, then go to **MX** and drag **Door 3D View** to a page.

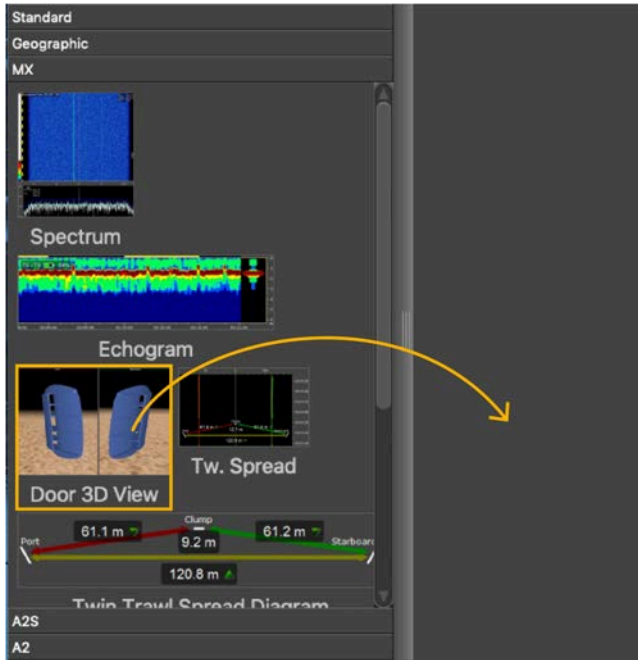

- Select the fishing gear element to be displayed in 3D. For multiple trawls, you can display the doors and clumps.

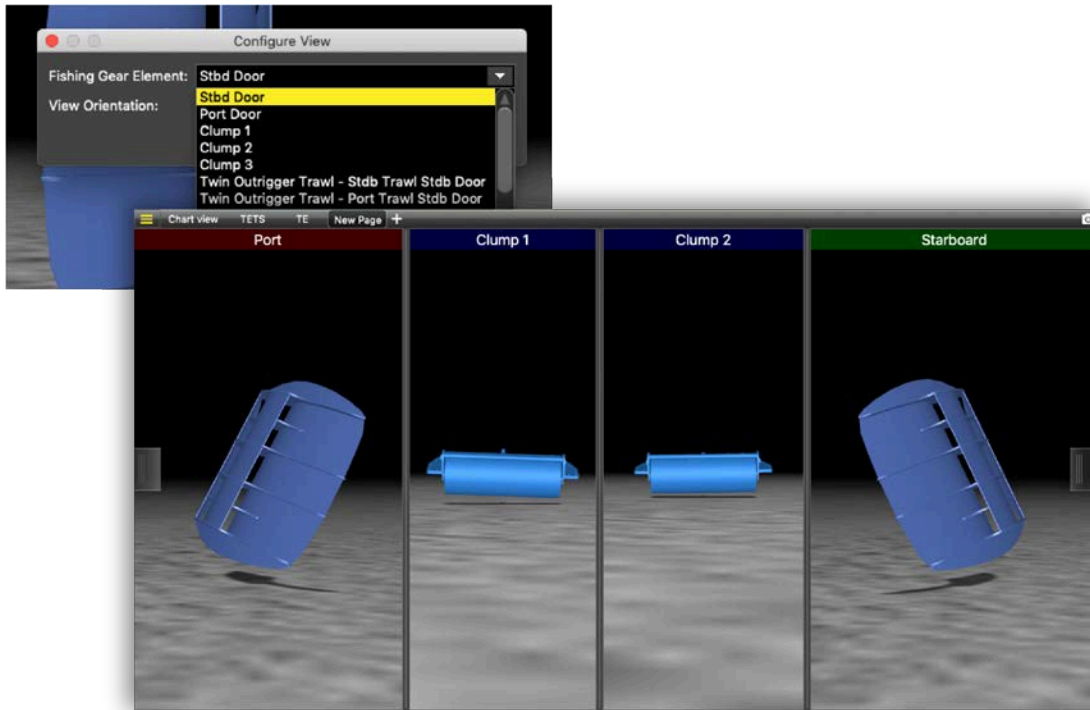

- From **MX**, drag **MultiTrawl** to the page. In **Input**, select the name of the receiver.

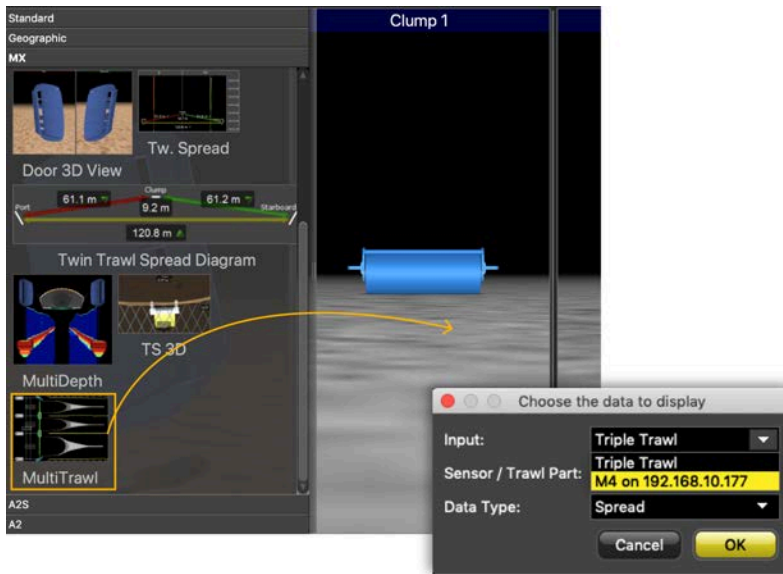

5. Open the control panel and go to **Mx** to add other data, such as depth, pitch and roll.

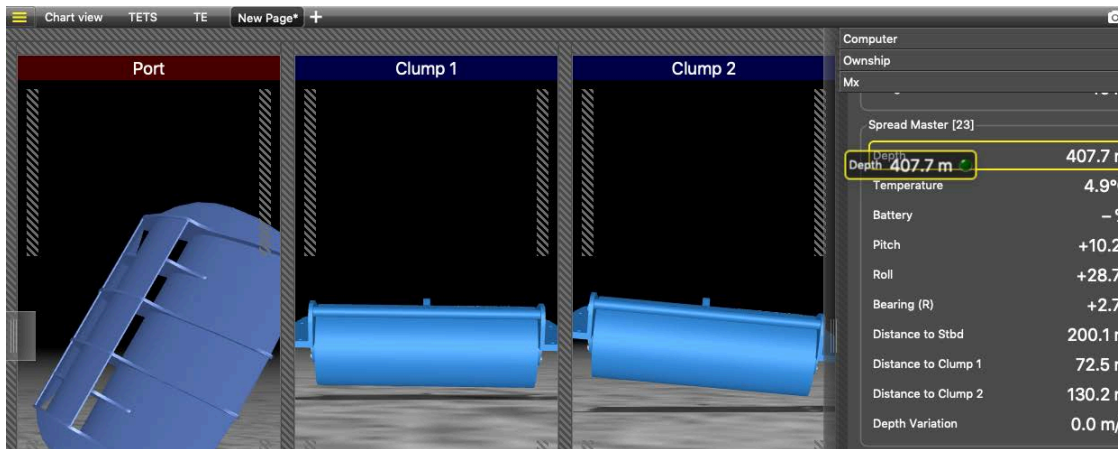

6. Select the type of display.

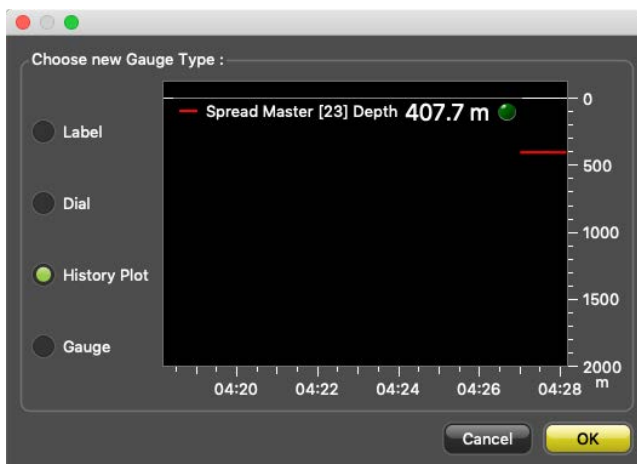

7. Drag the lines around the blocks of data to resize them.



- To save the changes, right-click the tab with the name of the page and click **Save Changes**.

Results

When you have finished customizing the page, you can have a screen display such as in this example.

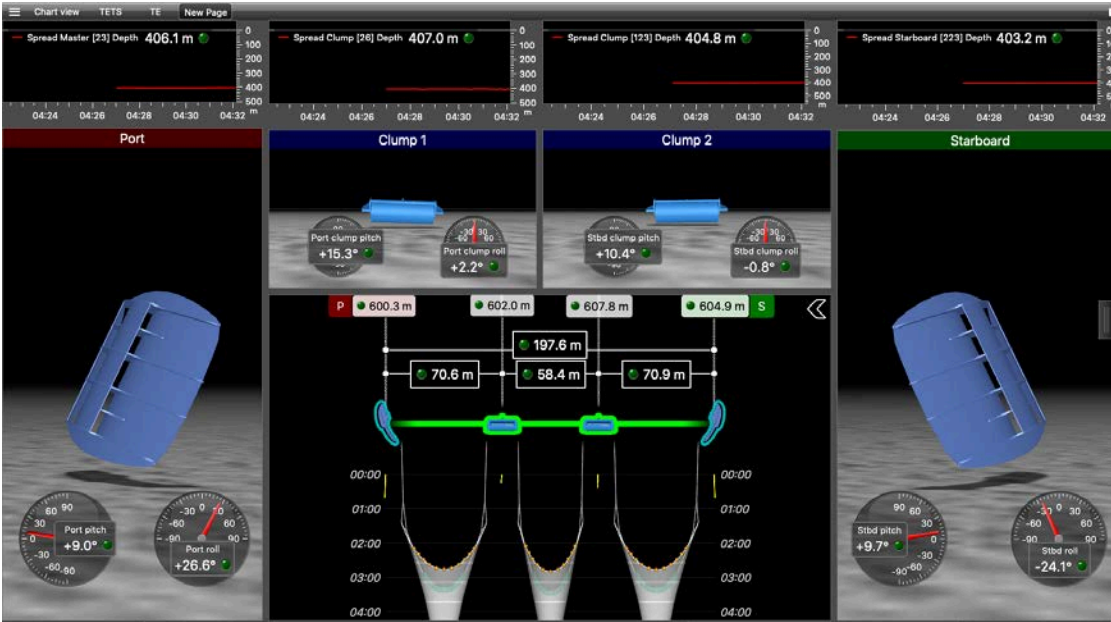

What to do next

Read [Display Options](#) on page 49 and [Understanding the MultiTrawl View](#) on page 52 for more details about the view.

Using the MultiTrawl View on Scala2

You can display a global 3D view of the trawl gear.

Displaying the MultiTrawl View

Before you begin

- Go to **Menu** ≡ > **Settings** > **Trawl**, then select **Auto** to automatically detect the number of trawls or select manually the type of trawl gear in use. If you change the trawl gear, change this setting accordingly.

Procedure

- Click **Menu** ≡ > **Customize** and enter the password eureka.
- Open the **Customize** panel on the left side of the screen, then drag **MultiTrawl** to a page.

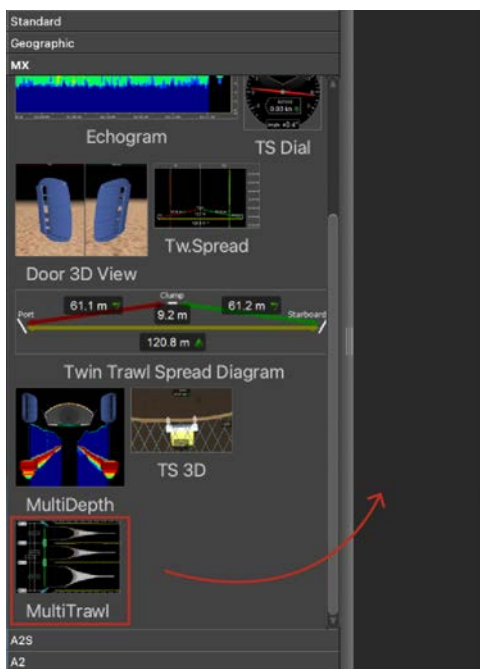

- Right-click the view to see display options. See [Display Options](#) on page 49.

Display Options

You can change the display of the **MultiTrawl** using customization panels. Right-click the view to open them.

Controls

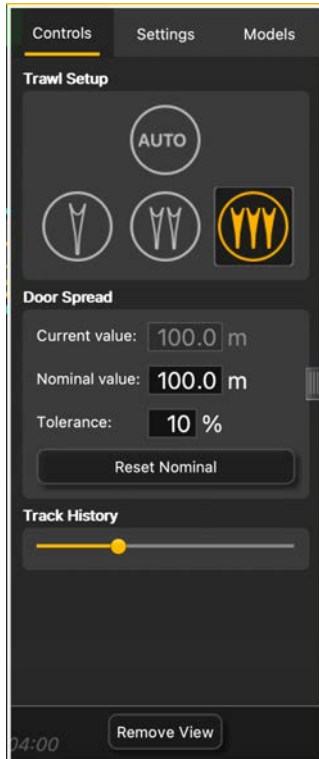

- **Trawl Setup:** select **Auto** to automatically detect the number of trawls or select manually the type of trawl gear in use. If you change the trawl gear, change this setting accordingly.
- **Door Spread:**
 - **Current value:** current total spread distance.
 - **Nominal value:** total spread distance you want to have. If the value of the current distance becomes larger or smaller than the nominal value, the alignment axis appears in red.
 - **Tolerance:** tolerance threshold between the current and nominal values.
- **Reset nominal:** if the current spread distance is correct, click to make this distance the nominal value.
- **Track History:** zoom in and out of the time scale of the trawl tracks.

Settings

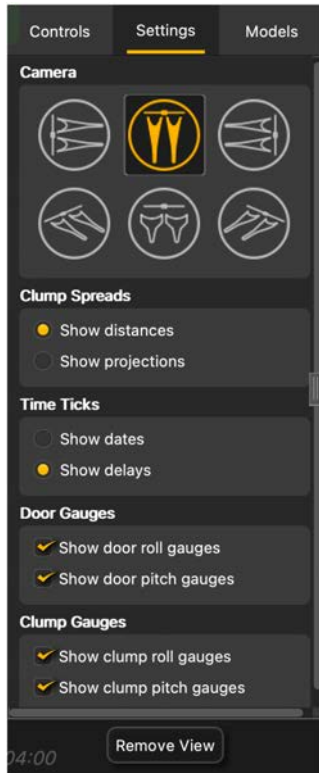

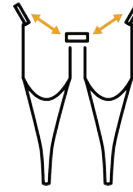

- **Camera:** change the viewing angle of the 3D view.
- **Clump Spreads:**

- **Show distances:** real values of spread between two door sensors.

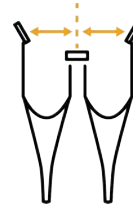

- **Show projections:** calculated values of linear spread between door sensors. These values have a yellow dot instead of a green dot.



 **Note:** Spread distances and projection distances should be the same. If not, it means the doors or clumps are not aligned.

- **Time Ticks:** select **Show dates** to show the current time on the timescale or **Show delays** to show the time that has elapsed since the trawl was put in water.
- **Warp Labels:** display the warp lengths received from a winch control system or the slant distance received from a Duplex sensor.
- **Door Gauges and Clump Gauges:**
 - **Show roll gauges** and **Show pitch gauges:** displays angular gauges to help with door pitch and roll monitoring.

Models

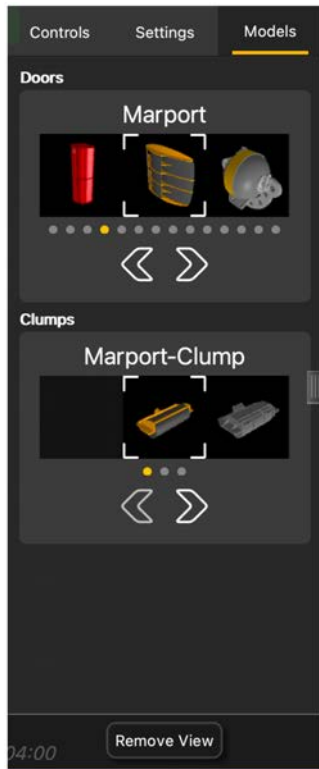

You can change the model of trawl doors or clumps.

Click the arrows to select the model. The 3D view will change accordingly.

Understanding the MultiTrawl View

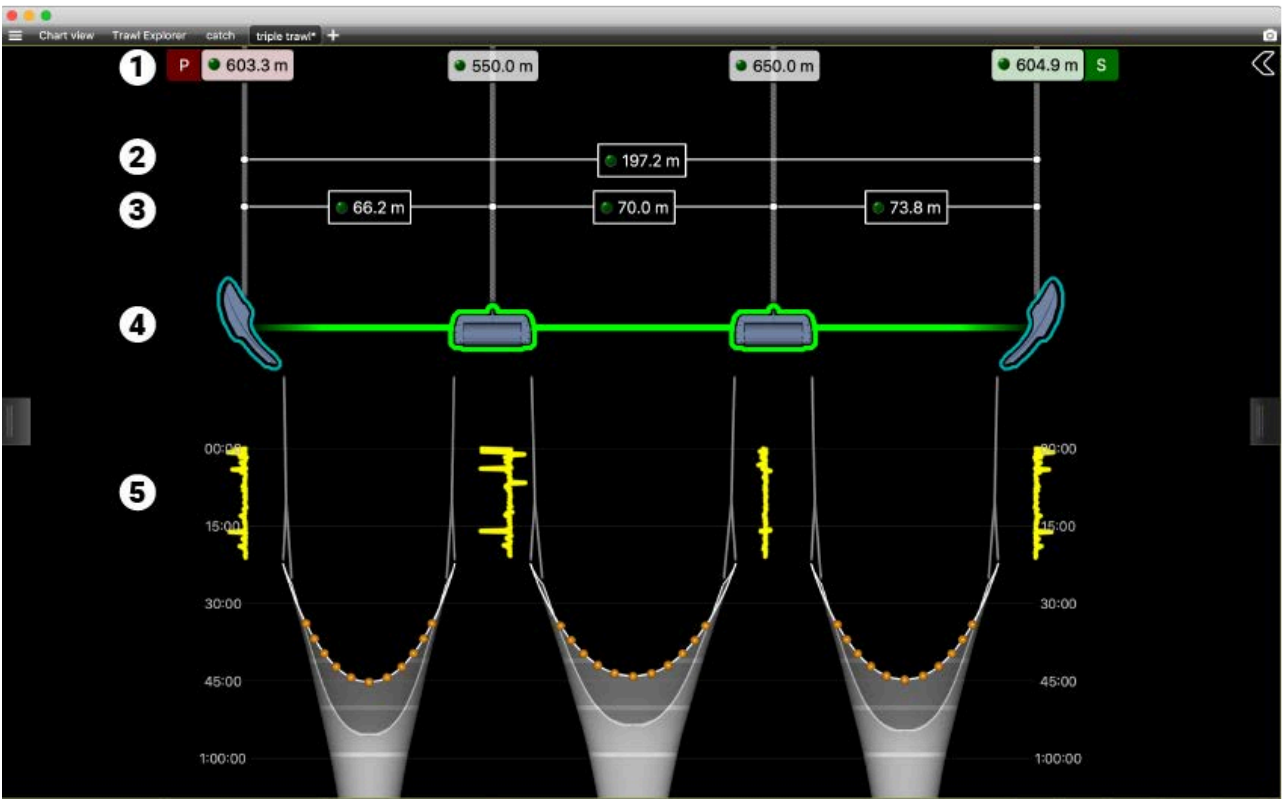

1. Warp lengths, received from a winch control system using NMEA sentences.
2. Total spread distance.
3. Spread distances between doors and clumps (or between doors for a single trawl).
4. 3D representation of the position of the doors and clump. Alignment is correct when the doors are inside their outline, clumps are framed in green and axis is green.
5. Track of the trawl doors and clumps. Timescale is on both sides of the trawls. Timescale can show the current time or the time that has elapsed since the trawl was put in water. In this example, the elapsed time is displayed.

Examples of data received

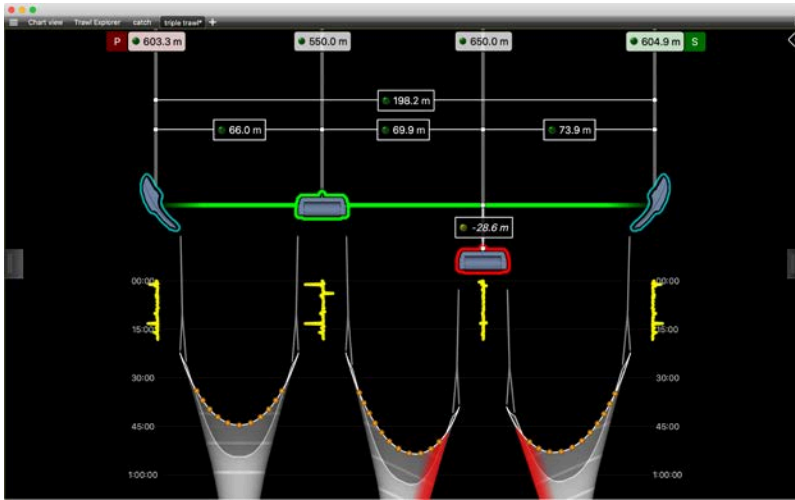

When a door or clump is out of alignment, it is displayed in red. The distance from the alignment axis is displayed above.

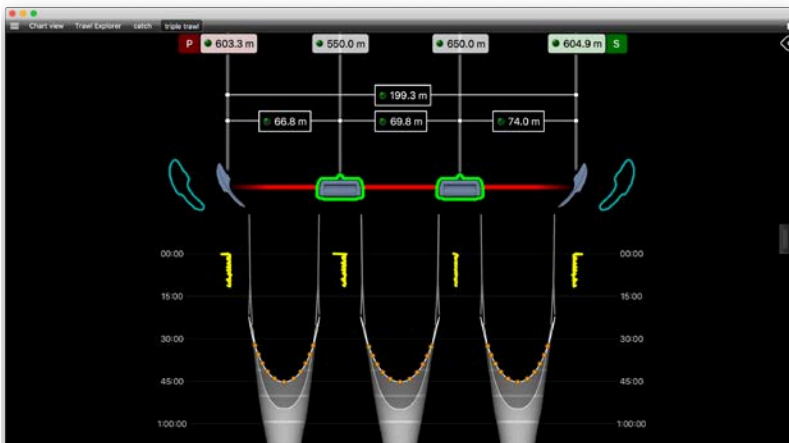

In this case, the current spread distance is inferior to the nominal spread distance that was set. Doors are shown out of their expected position and axis is in red.

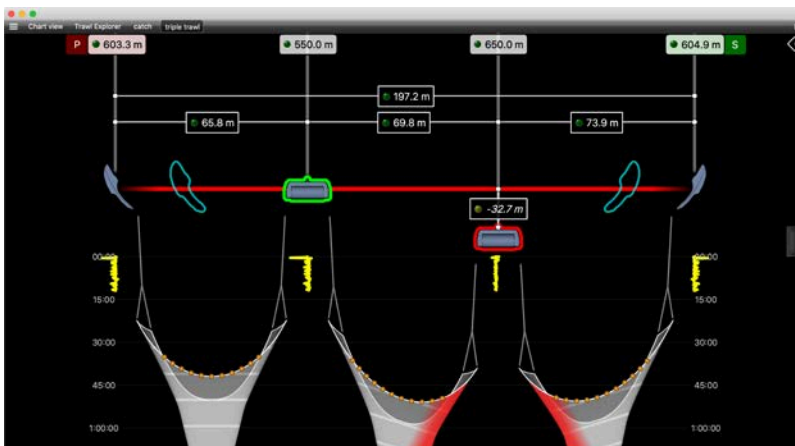

In this case, the current spread distance is superior to the nominal spread distance. One of the clump is out of alignment.

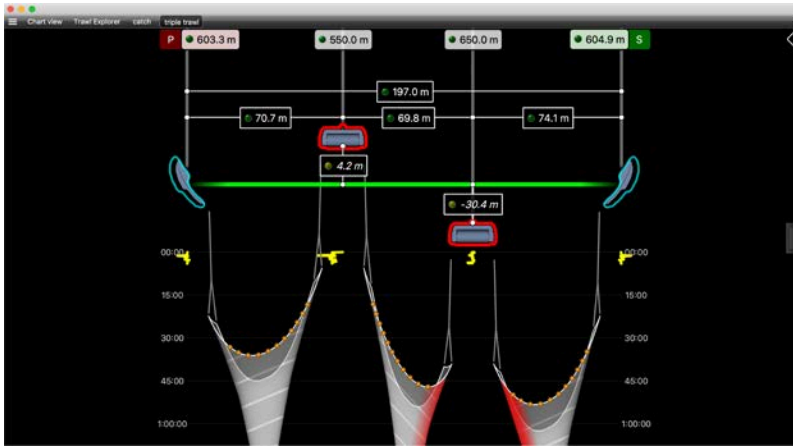

In this case, both clumps are out of alignment.

! Important: If you do not receive warp lengths, Scala2 is not able to show the correct position of the clumps. By default, Scala2 will display the clumps in a static position out of the alignment axis, closer to the vessel.

Displaying Door Positioning Data

If the door sensors have the positioning option, you can display views showing the trawl position.

Doors Positioning Data

You can display data related to the position of the doors.

Before you begin

Note: Minimum data required to display **Doors Positioning** are GPS positioning, depth, door spread distance, port and starboard door bearings. However, we strongly recommend to receive warp lengths from a winch control system. Without it, the accuracy of the positioning will be reduced.

Procedure

In the control panels, go to the trawl data. The name of the panel depends on the trawl gear setup. The panel can display **Single Trawl**, **Twin Trawl**, **Triple Trawl** or **Quad Trawl**.

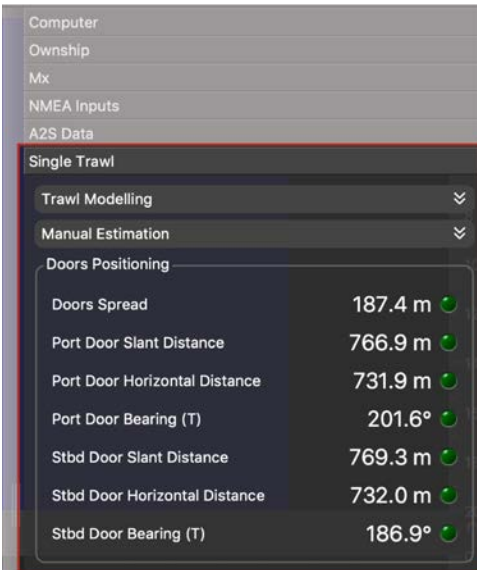

i Tip: This panel displays the door horizontal distance (1) and estimated slant distance (2) to the boat:

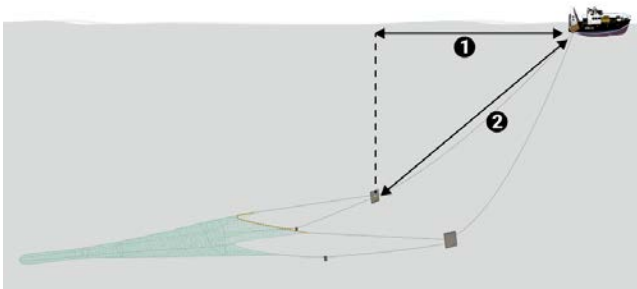

Displaying the Chart View

Before you begin

- You must be in **Customize** mode to do this task.

You must have:

- Incoming GPS data and heading data.
- Warp lengths or Duplex sensors giving distance to vessel.
- Spread sensors or Duplex sensors with bearing measurement

Procedure

- Open the customization panel, then go to **Geographic**.
- Click + drag **Chart** to the page.

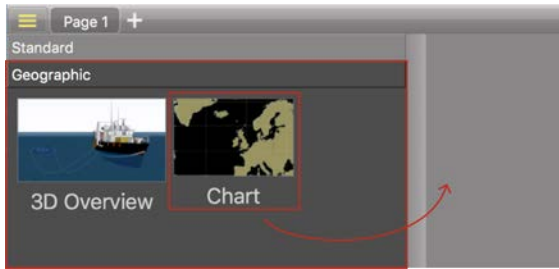

- Drop it in a yellow area.

The chart view is displayed. The heading of the vessel, the port (red) and starboard (green) door paths appear by default.

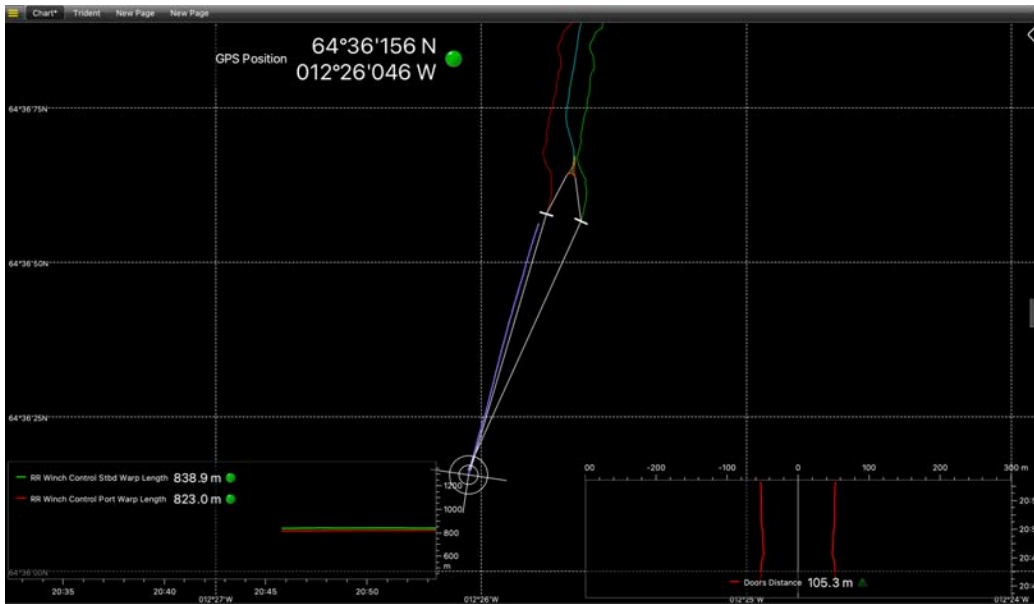

- To customize the display, right-click the page to display the setting menu.

 **Trouble:** If the view looks empty it might be because the view is not centered on the vessel. Open the setting menu and click **View > Center on Ownship** or **Center on Ownship and Trawl**.

Bearing Angles

Procedure



Scala2 displays the relative (R) bearing angles of the doors. Angles are relative to the stern of the vessel. Angles toward port side are negative and angles toward starboard side are positive. See for drawings.

Changing the Number of Trawls

You need to remove specific clumps when reducing the number of trawls in water.

To have correct door spread values displayed on Scala2, you need to be careful when you reduce the number of trawls. Door sensors are configured to operate on specific locations on doors and clumps. If the composition of the trawl gear does not correspond to the configuration of the sensors, spread data will not be displayed.

Triple trawl

-  Distances sent by Master on port door
-  Distance sent by inner port clump
-  Distance sent by inner starboard clump

- Triple trawl:

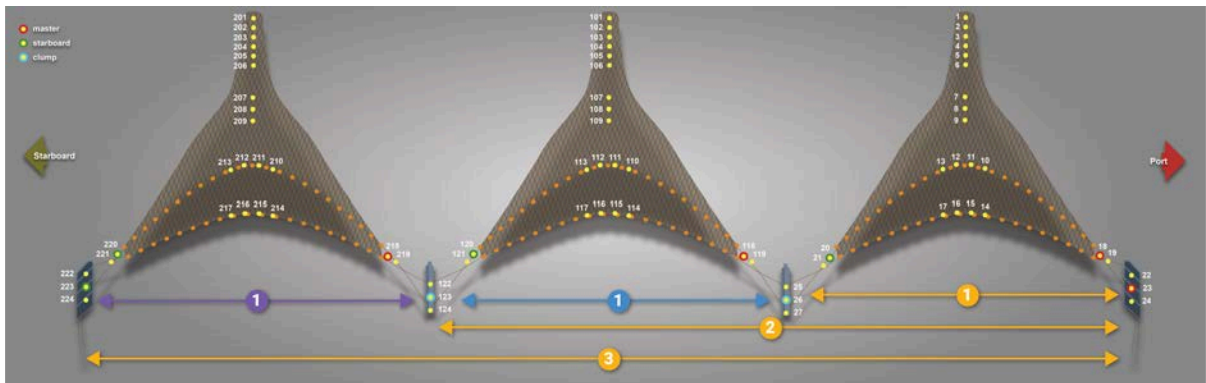

- Triple to twin: keep the inner starboard clump in water.

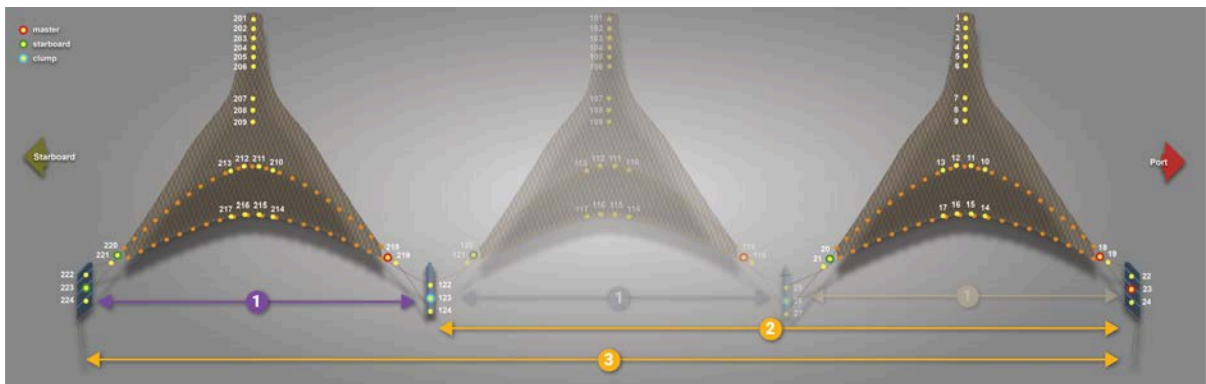

- Triple to single: only keep the starboard and port trawl doors in water.

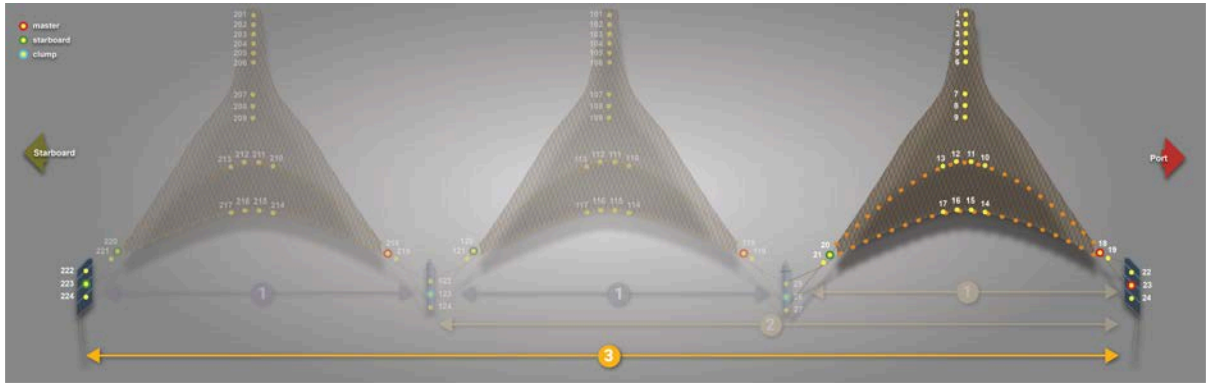

Quadruple trawl

- ← 1 → Distances sent by Master on port door
- ← 1 → Distance sent by inner port clump
- ← 1 → Distance sent by center clump
- ← 1 → Distance sent by the inner starboard clump

- Quadruple trawl:

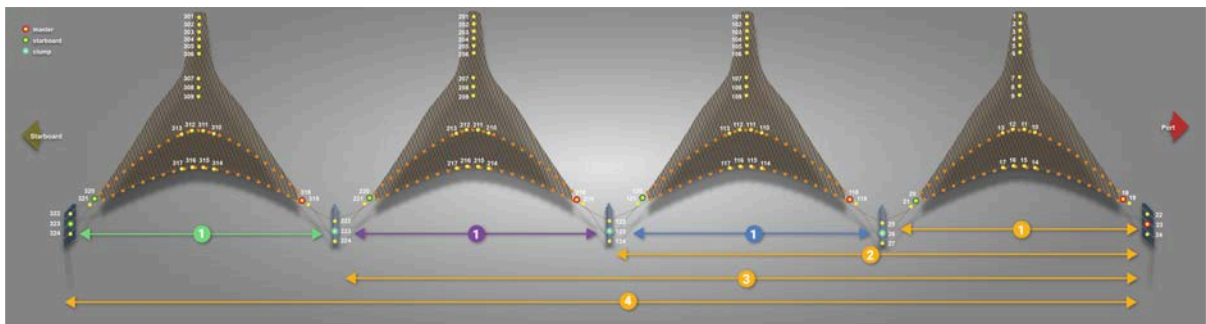

- Quadruple to triple: keep the center and inner starboard clump in water.

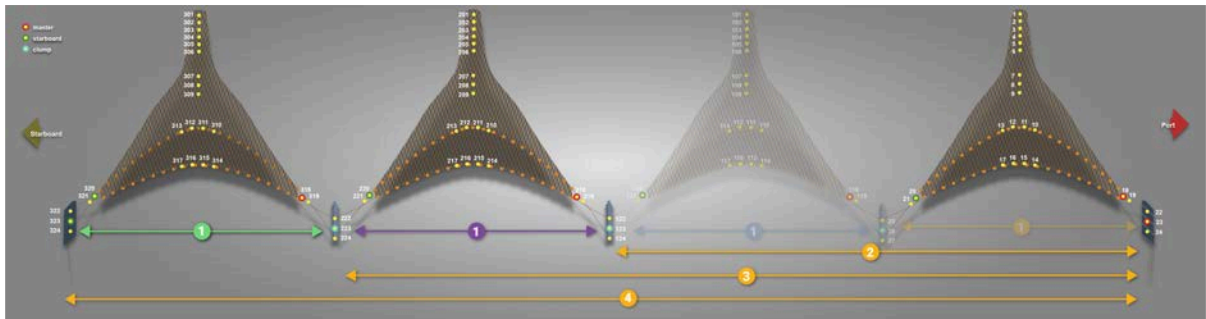

- Quadruple to twin: keep the inner starboard clump in water.

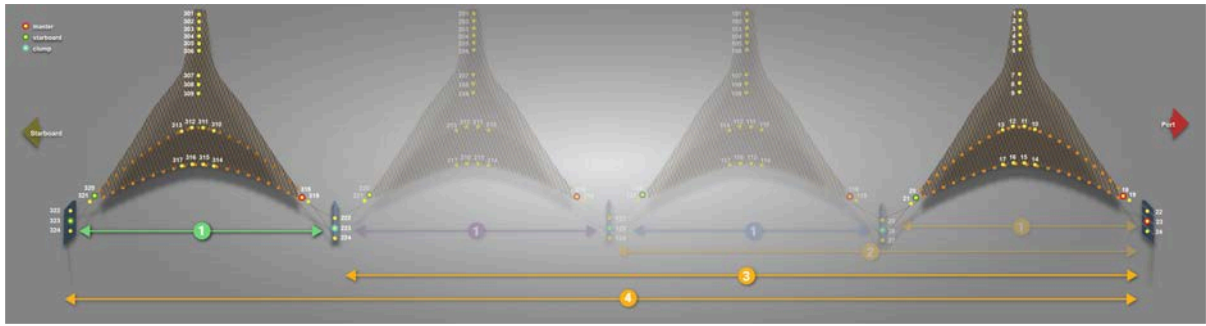

- Quadruple to single: only keep the port and starboard doors in water.

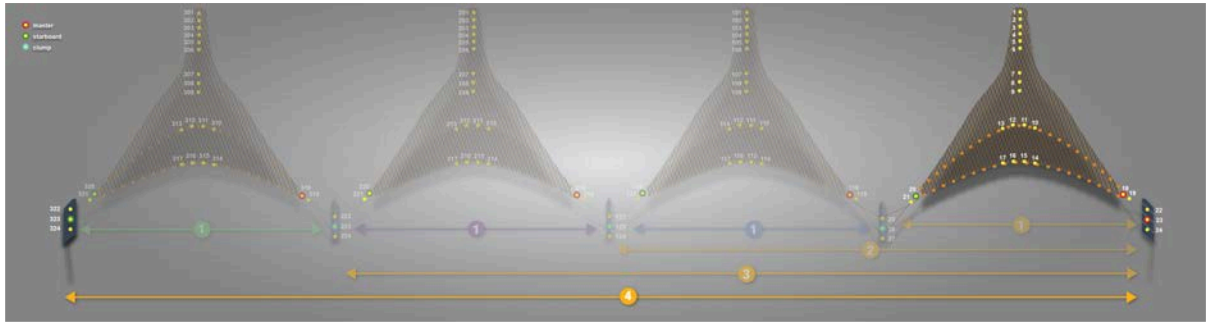

Installation

Learn how to install the sensor on the trawl gear.

Installation Principles

Door sensors need to be installed in pockets welded on trawl doors. Carefully read these installation principles before installing sensor pockets.

Angle of Attack

The angle of attack is the angle of the door in relation to the towing direction. This angle is important for the efficiency of the doors. It varies between trawl door models, so refer to manufacturer to know the exact angle. The angle is usually from 25° to 40° .

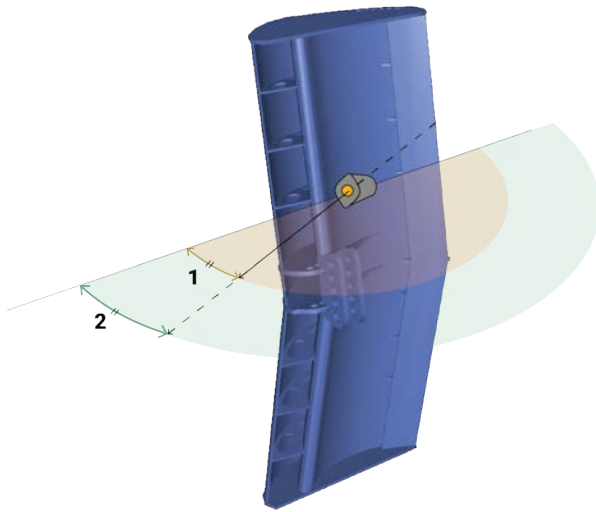

1. Angle of attack: $25-40^{\circ}$
2. Opening angle $25-40^{\circ}$

Opening and Elevation Angles

The opening and elevation angles depend on the pocket installation on the door.

The opening angle is the horizontal angle of the pocket in relation to the door. It should be between 25° and 40° . Opening angles should be in line with the angle of attack. You need to indicate the opening angle on Mosa2.

The elevation angle, or tilt angle, is the vertical angle of the pocket in relation to the door. It should be between 15° and 20° . The sensor must point toward the vessel: adjust the elevation angle based on the operational depth of the door during fishing operations.

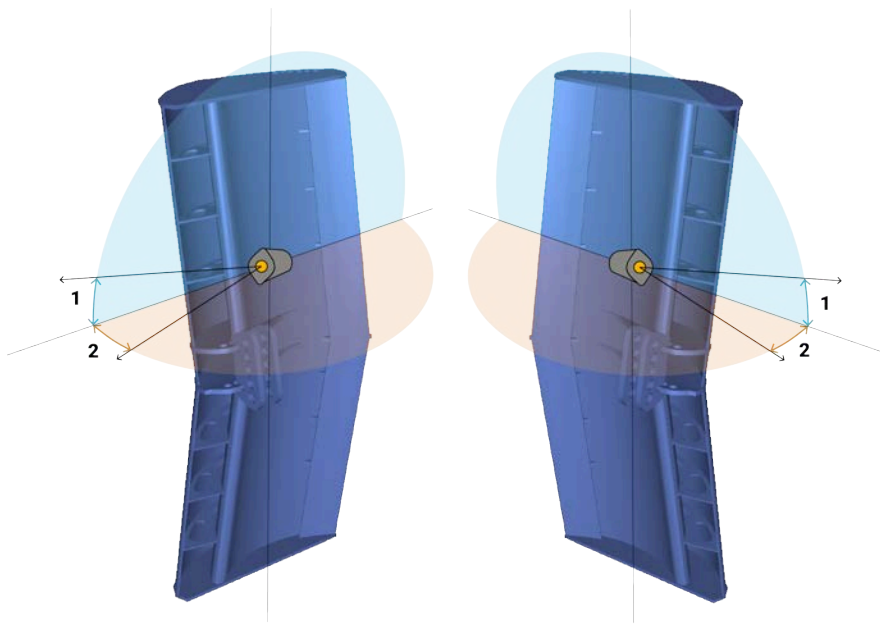

- 1. Elevation angle:
15-20°
- 2. Opening angle:
25-40°

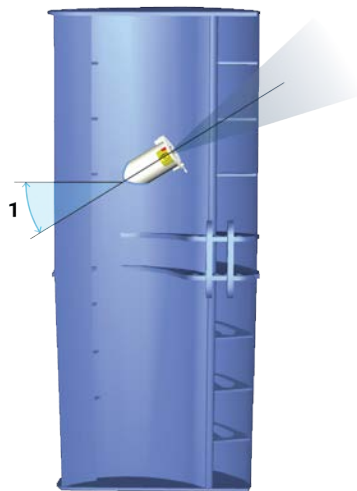

- 1. Elevation angle: 15-20°

Roll Angles

Roll angle of the sensors depends on the tilt of the doors when fishing. If doors are straight during fishing, you can apply a roll angle of 90°. If doors are tilted inward during fishing, slightly roll the pocket so that lines of communication between the sensors stay aligned. If not, you will have sporadic spread readings.

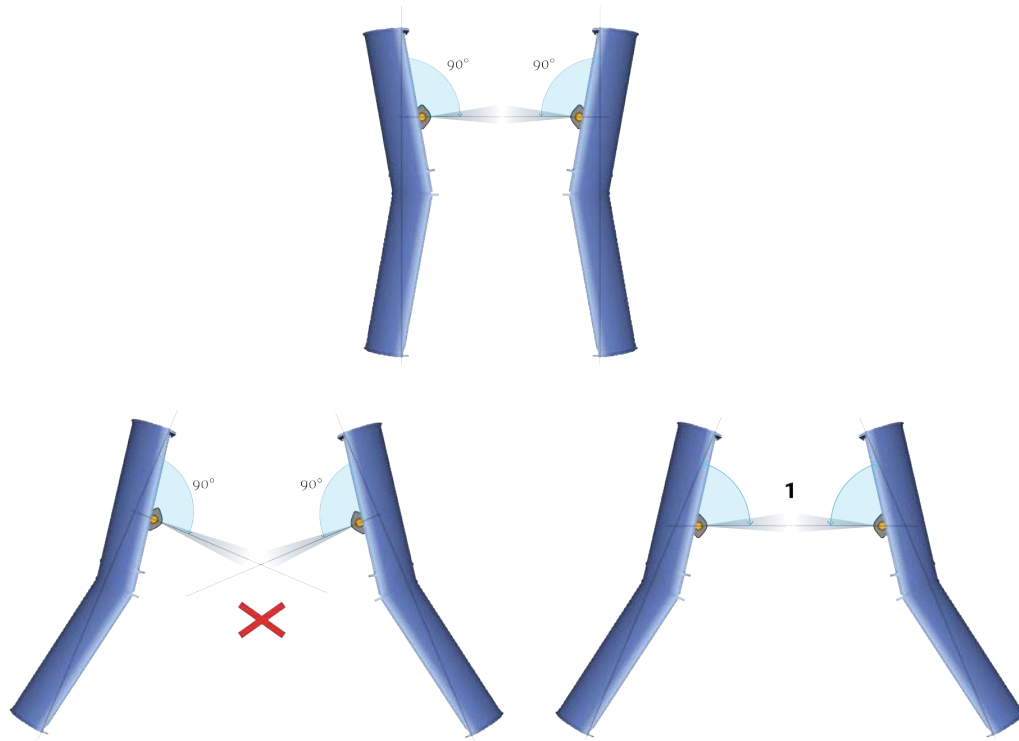

1. Adapt roll angles of pockets according to the tilt of the doors.

Communication

Spread sensors communicate with each other and with the receiver. Lines of communication between them and toward the receiver must be unobstructed.

The beamwidth toward the receiver (uplink ping) is 46° and beamwidth toward the other sensors (down ping) is 26° . This beamwidth is thinner: this is why it is important to keep sensors aligned.

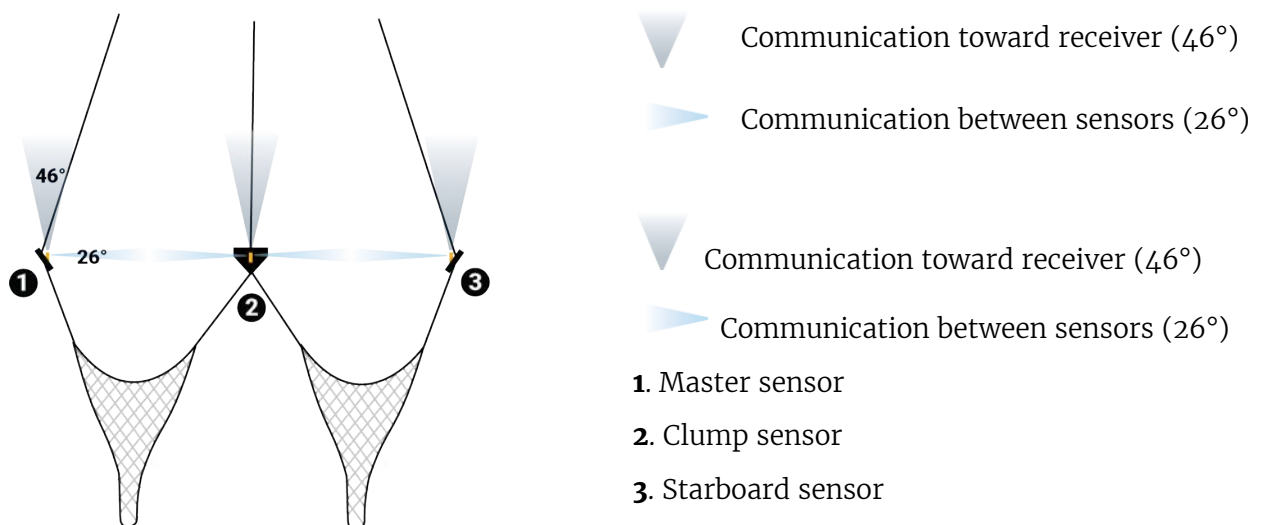

The side of the transducer with an A/circle must be oriented:

- Port sensor: toward starboard
- Clump and starboard sensors: toward port

Installing Sensor Pockets

You need to install pockets on each trawl door to hold the door sensors.

Before you begin

- Read [Installation Principles](#) on page 60 to become familiar with installation requirements.

See [Pocket Drawings](#) on page 87 to know which installation you need.

About this task

- ! Important:** Make sure you install the sensor pockets in accordance with the [installation principles](#): pockets are important for the correct functioning of the sensors. If they are misaligned or if the pocket hides the sensor signal, you will have issues receiving data.
- ! Important:** We strongly recommend to have alignment bars inside the pockets to hold the sensor in the correct position.
- ! Important:** Take care to gather as much information as possible from the trawl doors manufacturer before installation. Such as the angle of attack and towing angle.
- 🔧 Note:** If your door model have the doors rigged “nose up” or “nose down”, you need to change the angle of the door pockets so that the sensor always point toward the bottom of the ship when being towed.



Figure 1: Nose down (left) and nose up (right)

- 🔧 Note:** If you use the sensors for bottom trawling, install pockets on the upper part of trawl doors. Make sure the pocket's position does not influence too much the center of gravity of the door. Refer to door manufacturer for details.

Procedure

1. Use drawings of door pockets to mark the shape to be cut off: [Pocket Drawings](#) on page 87.
 - 🔧 Note:** Ask your local Marport sales office for scaled templates of door pockets.
2. Cut round openings in the doors.



3. Place the sensor pocket with the bottom portion sticking out of back side of the door. Adjust accordingly to the elevation angle and angle of attack you need (see [Pocket Angle of Attack](#) on page 88). Picture below shows angles of attack seen from above the door.

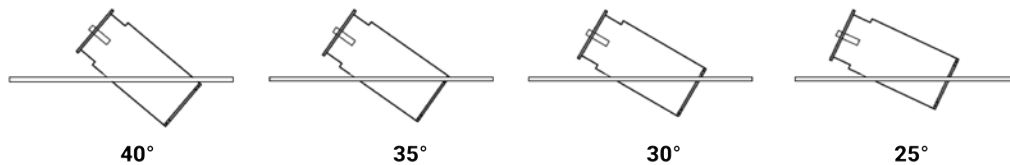

4. You can trace a line with a marker around the pocket at the point it enters the door to remember the correct position.
5. Check if angles are correct:
 - a) Weld only a few points on two sides of the pocket to hold it on the door.
 - b) Open Mosa2 software.
 - c) Activate and deactivate the water-switch to connect the sensor to Mosa2 via a wireless signal.
 - d) Go to **Measurements** page and click  in **Motion**.
 - e) Check on the bottom of the window that the pitch and roll of the door are close to 0 degree.
 - f) If you do not have Mosa2 software, manually check the angles.
6. If values are not correct, move the pocket, then check again.
7. If values are correct, permanently weld the pocket to the door.

8. We recommend to use a protective cage made of metal bars around pockets to protect sensors, like the examples below.



 **Note:** Make sure there is sufficient space between the protective cage and the sensor pocket, so that if the cage becomes bent, you can still remove the sensor.

Maintenance and Troubleshooting

Read this section for troubleshooting and maintenance information.

! Important: Only an approved Marport dealer can access the internal unit. Warranty will become void if anyone other than an approved dealer tries to do internal maintenance duties on the sensor.

Charging the Sensor with the Dock

Connect a sensor to one of the 4 charging connectors of the Dock to display its level of charge.

Before you begin

- Make sure the Dock is connected to a power supply and turned on.

About this task

! Warning: In case of water ingress in the product, do not charge it: battery may vent or rupture, causing product or physical damage.

Note: For Dock products with serial number before DOC2107XXX: Do not leave the sensors connected on a charger that is switched off. If the charger is not connected to the mains voltage, the sensor switches on and this will drain the battery.

Note: Avoid full discharges and charge the battery whenever possible, at any battery level. Lithium-ion batteries do not have a charge memory, so they do not need full discharge cycles.

Procedure

1. Before charging the sensor: wash with fresh water and dry the sensor. This prevent corrosion of the charging pins.

! Important: Check that the charging pins are not damaged. If they are, contact you local Marport dealer for replacement.

2. Connect the charger plug to one of the 4 charging ports.

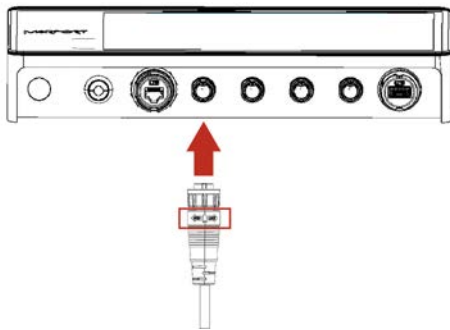

3. Connect the 3-pin charging connector to the sensor charging pins.

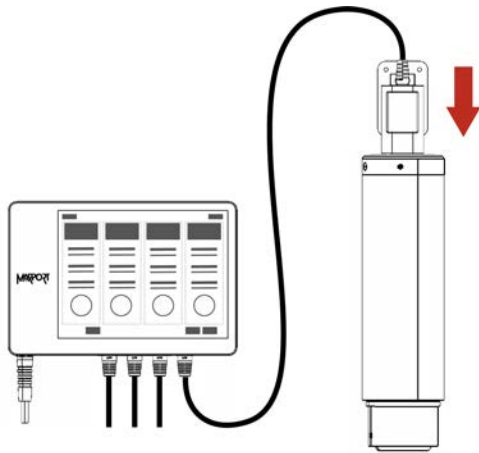

Results

The Dock screen and Virtual Charger Room display the state of charge of the sensor.

Cleaning the Sensor

You need to regularly clean the sensor for proper performance.

Wash the sensor with fresh water and dry it before you charge or store it.

Regularly check that the sensor is clean. If not:

- Remove any marine life with a piece of wood or screwdriver.
- Wash away mud or debris with warm water.

⚠ CAUTION: Do not use highly abrasive materials or jet wash.

⚠ CAUTION: Special care should be taken with sensors and components sensitive to mechanical shock or contamination.

Maintenance Checklist

We recommend you to follow this maintenance schedule for better performance and to avoid any trouble with the equipment.

Before use	<ul style="list-style-type: none"> • Check that all attachment equipment are not worn or torn. Replace when appropriate. • Check that the sensor is clean. See Cleaning the Sensor on page 67 for cleaning procedures. • Check the battery level 24 hours before use and recharge if necessary.
After use	Wash the sensor with fresh water.
Between uses	When the sensor is not in use, store in a dry area, without humidity, at a temperature between -10° and 70 °C (14 to 158 °F).
Not used for more than 3 months	<ul style="list-style-type: none"> • Do not leave the batteries at full charge or discharged for a long period of time or they will wear out. • Every 6 months, put the sensor in charge for less than an hour.
Every 2 years	The sensor must be returned to an approved Marport dealer for inspection and maintenance.

If the sensor has not been not used for more than 3 months, we highly recommend to check the following points before using it:

- Make sure the sensors on the end cap are in good condition and clean.
- Connect the sensor to a charger and check the charging status.
- Switch on the sensor by shorting the center lug to the negative lug, then listen for a ping noise and check if you see the LED switched on.
- Test the sensor measures with Mosa2: depth, temperature, pitch, roll, and if applicable: spread distance, echogram, catch status, speed measures (using the EM log tester).
- If you have a test hydrophone, check the reception in the wheelhouse with Scala.

Troubleshooting

Learn how to solve common problems.

Mosa2 does not open due to error message

Mosa2 displays an error message saying it cannot be opened.

→ Your Mac security preferences do not allow you to open applications not downloaded from the App Store.

1. From the upper left corner of the screen, click **Apple menu** > **System Preferences** > **Security & Privacy**.
2. Click the lock icon and enter the password, if applicable.
3. At **Allow apps downloaded from**, select **Anywhere**, then close the dialog box.
4. **macOS Sierra or later: Anywhere** option is not displayed by default. To display **Anywhere**:
 1. Click the magnifying glass from the top right corner of your screen and type `Terminal`.
 2. Click **Terminal** from the results.
 3. Enter in the terminal: `sudo spctl --master-disable`.
 4. Press Enter.

Anywhere option is now displayed in **Security & Privacy** preferences.

Sensor does not connect correctly with Mosa2 when using the Configuration Cable



Remember: If the sensor does not connect correctly with Mosa2, always:

- Disconnect both USB connector and three-pin plug.
- Connect again the Configuration Cable.
- Make sure the three pins are fully inserted inside the sensor.

→ Mosa2 does not automatically open when connecting the Configuration Cable.

- Check that you see Marport Captain icon in the desktop taskbar. If you do not see it: close, then open Mosa2. The icon should appear in the taskbar.



Note: Marport Captain is a program running in the background. It allows Mosa2 automatic opening and displays shortcuts to Mosa2 and Scala applications installed on the computer. It should not be closed.

- If the problem persists, install Mosa2 again.

→ At the end of step 2 of the configuration wizard, the sensor does not respond.

- Connect the sensor to a charger and wait until it is fully charged.

→ The sensor has been disconnected from Mosa2.

- Check that the Configuration Cable is not connected to a USB hub. The Configuration Cable must be connected directly to the computer.

- If the computer goes to sleep mode, the sensor may be disconnected. Change the settings on your computer to increase the time before sleep mode.
 - If the problem persists, connect the sensor to a charger and wait until it is fully charged. Then try again to connect.
- Mosa2 displays a critical error message.
- Disconnect both USB connector and three-pin plug. Then, connect again the Configuration Cable. If the message is still displayed, it means there is an issue with the sensor's components. Contact Marport support.

Chart and 3D Views Are Wrong

Tip: If the position of the trawl is wrong, open the control panels and click **Reset Trawl Position** in **Trawl Modeling** data.

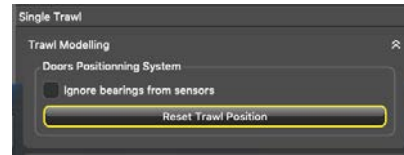

The trawl is placed incorrectly

- The positioning settings may be incorrect.
1. From Scala2, click **Menu** ≡ > **Expert Mode**.
 2. Right-click the IP address of the receiver at the bottom of the page, then click **Configure Receiver**.
 3. From the left side of the screen where the system is displayed, click **Positioning**.

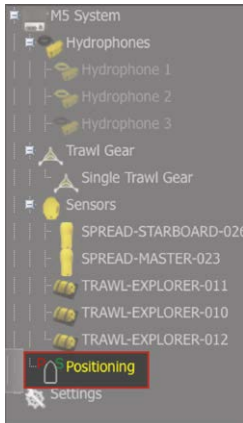

4. Check that the settings are correctly completed. See [Configuring the Positioning Settings](#) on page 33

There is no trawl on Scala2, MaxSea or Olex

- Trawl settings may be incorrect.
1. Open the control panels and check from the Trawl data that you see data in **Doors Positioning**.

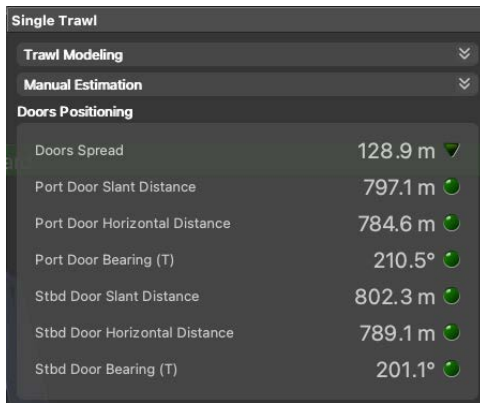

2. Click **Menu** > **Settings** > **Trawl**.
3. Check that **Headline (H)**, **Bridle (B)** and **Sweepline (S)** dimensions are completed according to your trawl model.

There is no trawl or vessel

→ You may have no GPS coordinates or heading data.

1. Open the control panels, then go to **NMEA Inputs** and check that you receive GPS coordinates and heading data.

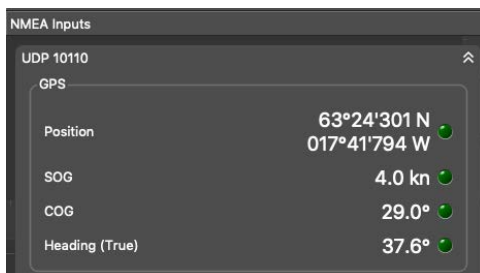

2. If not, check you have correctly configured the NMEA input(s): [Adding Data from External Devices](#) on page 36.

The trawl seems shrunken

→ Bearing angles may be incorrect.

Check the baseline dimensions you entered in the [positioning settings](#) in the system web page (or Scala2 receiver page).

The vessel and trawl have erratic movements: they jump, zigzag, move forward and backward

→ You have two GPS inputs. Coordinates can be slightly different between the two GPS so the position of the trawl changes according to one or the other.

Open the control panels and check if you receive coordinates from two GPS in **NMEA Inputs**. If so, remove one of the devices.

Positioning on SeapiX: Port/starboard trawl doors are reversed

→ NMEA output sentence may be wrong.

1. Go to **Settings** > **NMEA Outputs**.

2. Click the edit icon in front of the corresponding NMEA output.
3. Click **Data to Emit** tab, then check that **Emit trawl positioning sentence** is set to **Best sentence for Seapix (\$PTSAL)**.

In Scala2, Lost is displayed instead of spread distance

It is written **Lost** instead of spread distance data.



- Trawl doors may not be aligned or may lay on their side.
 1. Check the pitch and roll.
 2. If needed, pull the warps to align the doors or set them back upright.

- Master and Starboard sensors have been inverted on the doors. In that case, you will also have wrong pitch and roll values.
 - Open the pocket and check the top of the housing of the sensor: the one with a green marker must be on the starboard side and the one with a red marker on the port side. If there is no marker on the top, remove the sensor and check on the side if there is a marker. The side of the transducer with a circle must be oriented towards the outside.

- If you used to have correct data and suddenly lost them, the up or down component in the transducer may be broken.
 1. Remove sensors from the doors and check from the office if **Lost** is still displayed.
 2. If yes, see with support service for repair.

Support Contact

You can contact your local dealer if you need maintenance on your Marport products. You can also ask us at the following contact details:

FRANCE

Marport France SAS
8, rue Maurice Le Léon
56100 Lorient, France
supportfrance@marport.com

NORWAY

Marport Norge A/S
Breivika Industrivei 69
6018 Ålesund, Norway
supportnorge@marport.com

SPAIN

Marport Spain SRL
Camino Chouzo 1
36208 Vigo (Pontevedra), Spain
supportspain@marport.com

USA

Marport Americas Inc.
12123 Harbour Reach Drive, Suite 100
Mukilteo, WA 98275, USA
supportusa@marport.com

ICELAND

Marport EHF
Tónahvarf 7
203 Kopavogur, Iceland
supporticeland@marport.com

SOUTH AFRICA

Marport South Africa
Cape Town, Western Cape
11 Paarden Eiland Road
Paarden Eiland, 7405
csanter@marport.com

UNITED KINGDOM

Marport UK ltd
32 Wilson Street
Peterhead, AB42 1UD, United Kingdom
gyoungson@marport.com

Appendix

Frequency Plan

It is important to carefully plan the setup of your sensors before adding them to the system. You can create a table with a list of frequencies and complete it when you add sensors.

Boat & Channel Codes

This list shows the standard frequencies for PRP telegrams. When you configure boat codes, make sure to respect the correct interval between frequencies (see table above).

Codes		
BC/CH	Frequency	FID (Scanmar)
C-1/CH1	42833	45
C-1/CH2	41548	32
C-1/CH3	41852	35
C-1/CH4	40810	25
C-1/CH5	42500	42
C-1/CH6	43200	49
C-2/CH1	42631	43
C-2/CH2	41417	31
C-2/CH3	41690	33
C-2/CH4	40886	26
C-2/CH5	42300	40
C-2/CH6	43100	48
C-3/CH1	42429	41
C-3/CH2	41285	30
C-3/CH3	41548	32
C-3/CH4	40970	27
C-3/CH5	42100	38
C-3/CH6	43000	47
C-4/CH1	42226	39
C-4/CH2	41852	35
C-4/CH3	41417	31
C-4/CH4	41160	29

C-4/CH5	42700	44
C-4/CH6	43300	50
C-5/CH1	42024	37
C-5/CH2	41690	33
C-5/CH3	41285	30
C-5/CH4	41060	28
C-5/CH5	42900	46
C-5/CH6	43400	51
C-6/CH1	39062	3
C-6/CH2	39375	7
C-6/CH3	39688	11
C-6/CH4	40000	15
C-6/CH5	40312	19
C-6/CH6	40625	23
C-7/CH1	38906	1
C-7/CH2	39219	5
C-7/CH3	39531	9
C-7/CH4	39844	13
C-7/CH5	40156	17
C-7/CH6	40469	21

Frequencies and intervals

The diagrams below show the bandwidth of the different types of Marport sensors and intervals you must respect when adding other sensors.

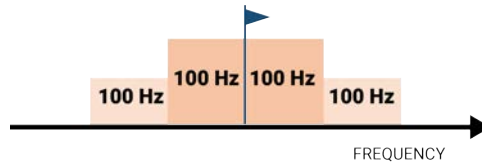

Figure 2: PRP sensors (e.g. Catch sensor, Trawl Speed, Spread sensor...)

Example: If the frequency of the sensor is 40kHz, there should be no sensors between 39.9-40kHz and 40-40.1kHz.

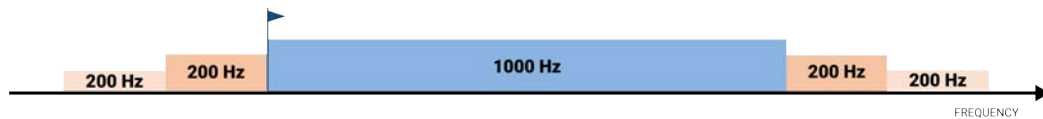

Figure 3: Marport Pro sensors (e.g. Trident, Door Explorer)

Example: If the frequency of the sensor is 40kHz, there should be no sensors between 39.8-40kHz and 40-50.2kHz.

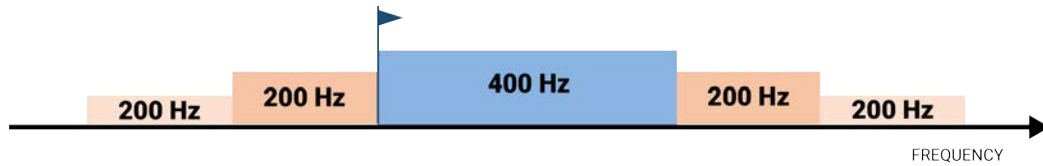

Figure 4: NBTE sensors (e.g. Speed Explorer, Trawl Explorer, Catch Explorer, Door Sounder)

Example: If the frequency of the sensor is 40kHz, there should be no sensors between 39.8-40kHz and 40-40.6kHz.

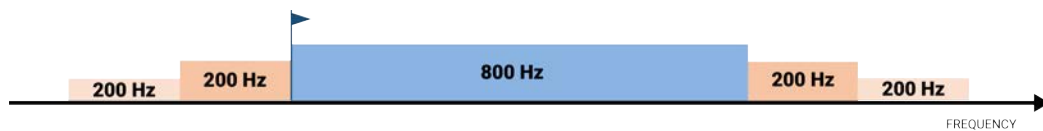

Figure 5: HDTE narrow band mode

Example: If the frequency of the sensor is 40kHz, there should be no sensors between 39.8-40kHz and 40-41kHz.

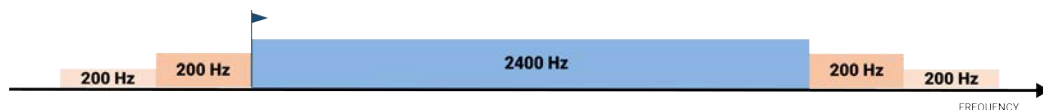

Figure 6: HDTE wide band mode

Example: If the frequency of the sensor is 40kHz, there should be no sensors between 39.8-40kHz and 40-42.6kHz.

▶ Frequency of the sensor ■ Bandwidth ■ Mandatory distance with other sensors ■ Recommended distance with other sensors

Examples of frequency allocations

- We recommend to allocate frequencies between 34 and 56 kHz for wideband hydrophones and between 41 kHz and 44 kHz for narrowband hydrophones.
- Echosounders are usually placed around 38 kHz, make sure to allow enough distance with them.

Compatible NMEA Sentences from Winch Control Systems, GPS and Compass Devices

You can add to Scala2 measures coming from winch control systems that use the following NMEA sentences.

NMEA 0183 Standard Sentences

Symbol (*) indicates which parts of the sentence Scala2 uses.

NMEA Sentence	Format	First compliant version of Scala
GGA - Global Positioning System Fix Data	<pre>\$--GGA,hhmmss.ss,aaaa.aa,b,cccc.cc,d,e,ff,g.g,h.h,M,i.i,M,j.j,kkkk*hh<CR><LF></pre> <ol style="list-style-type: none"> 1. \$--: Talker identifier* 2. GGA: Sentence formatter* 3. hhmmss.ss: UTC of position* 4. aaaa.aa, b: Latitude North/South (N/S)* 5. cccc.cc, d: Longitude East/West (E/W)* 6. e: GPS quality indicator 7. ff: Number of satellites in use (00-12) 8. g.g: Horizontal dilution of precision 9. h.h, M: Antenna altitude above/below mean sea level (geoid), meters* 10.i.i, M: Geoidal separation, meters 11.j.j: Age of differential GPS data 12.kkkk: Differential reference station ID 13.*hh: Checksum* 	1.0.0.0
GLL - Geographic Position - Latt/Long	<pre>\$--GLL,aaaa.aa,L,bbbb.bb,L,hhmmss.ss,C,d*hh<CR><LF></pre> <ol style="list-style-type: none"> 1. \$--: Talker identifier* 2. GLL: Sentence formatter* 3. aaaa.aa,L: Latitude North/South (N/S)* 4. bbbb.bb,L: Longitude East/West (E/W)* 5. hhmmss.ss: UTC of position* 6. C: status (A= data valid / V: data not valid)* 7. d: Mode indicator 8. *hh: Checksum* 	1.2.6.0

NMEA Sentence	Format	First compliant version of Scala
GNS - GNSS Fix Data	<p>\$--GNS,hhmmss.ss,aaa.aa,L,bbbb.bb,L,c--c,dd,e.e,f.f,g.g,h.h,i.i,a*hh<CR><LF></p> <ol style="list-style-type: none"> 1. \$--: Talker identifier* 2. GNS: Sentence formatter* 3. hhmmss.ss: UTC of position* 4. aaaa.aa,L: Latitude North/South (N/S)* 5. bbbb.bb,L: Longitude East/West (E/W)* 6. c--c: Mode indicator 7. dd: Total number of satellites in use (00-99) 8. e.e: Horizontal dilution of precision 9. f.f: Antenna altitude above/below mean sea level (geoid), in meters* 10.g.g: Geoidal separation, meters 11.h.h: Age of differential data 12.i.i: Differential reference station ID 13.*hh: Checksum* 	1.0.0.0
HDG - Heading, Deviation & Variation	<p>\$--HDG,a.a,b.b,M,c.c,M*hh<CR><LF></p> <ol style="list-style-type: none"> 1. \$--: Talker identifier* 2. HDG: Sentence formatter* 3. a.a: Sensor magnetic heading (degrees)* 4. b.b,M: Magnetic deviation (degrees), Easterly/Westerly (E/W)* 5. c.c,M: Magnetic variation (degrees), Easterly/Westerly (E/W)* 6. *hh: Checksum* 	1.0.0.0
HDT - Heading, True	<p>\$--HDT,a.a,T*hh<CR><LF></p> <ol style="list-style-type: none"> 1. \$--: Talker identifier* 2. HDT: Sentence formatter* 3. a.a,T: Heading (degrees) True* 4. *hh: Checksum* 	1.0.0.0

NMEA Sentence	Format	First compliant version of Scala
RMC - Recommended Minimum Navigation Information	<p>\$--RMC,aaaaaa,A,bbbb.bbb,B,cccc.ccc,C,ddd.d,eee.e,ffffff,ggg.g,G,H*hh<CR><LF></p> <ol style="list-style-type: none"> 1. \$--: Talker identifier* 2. RMC: sentence formatter* 3. aaaaaa: Time (UTC)* 4. A: Status, A = data valid, V = navigation receiver warning* 5. bbbb.bbb, B: Latitude, N/S* 6. cccc.ccc, C: Longitude, E/W* 7. ddd.d: Speed over ground (knots)* 8. eee.e: Course Over Ground (degrees True)* 9. fffff: Date: ddmmyy* 10. ggg.g, G: Magnetic variation (degrees E/W)* 11. H: mode indicator: A=Autonomous, D=Differential, E=Estimated, M=Manual input, S=Simulator, N=data not valid (sentence is not accepted if mode indicator = N)* 12. *hh: Checksum* 	2.2.2.0
VHW - Water Speed and Heading	<p>\$--VHW,a.a,T,b.b,M,c.c,N,d.d,K*hh<CR><LF></p> <ol style="list-style-type: none"> 1. \$--: Talker identifier* 2. VHW: Sentence formatter* 3. a.a,T: Heading, degrees True* 4. b.b,M: Heading, degrees Magnetic* 5. c.c,N: Speed, knots* 6. d.d,K: Speed, km/hr 7. *hh: Checksum* 	1.4.0.0
VTG - Course Over Ground and Ground Speed	<p>\$--VTG,a.a,T,b.b,M,c.c,N,d.d,K*hh<CR><LF></p> <ol style="list-style-type: none"> 1. \$--: Talker identifier* 2. VTG: Sentence formatter* 3. a.a,T: Course over ground, degrees, True* 4. b.b,M: Course over ground, degrees, Magnetic 5. c.c,N: Speed over ground, knots* 6. d.d,K: Speed over ground, km/hr* 7. *hh: Checksum* 	1.3.3.0

Proprietary Sentences

Symbol (*) indicates which parts of the sentence Scala2 uses.

Sentence	Format	First compliant version of Scala2
<p>ATW - Naust Marine winch control system</p>	<p>\$NMATW, aaaaaa, bbbbbb, cccccc, ddddd, eeeee, fffff, ggggg, hhhhh, iiiii, jjjjj, kkkkk, lllll, mm:mm*hh <CR><LF> \$NMATW: Talker identifier + sentence formatter*</p> <ol style="list-style-type: none"> a. Winch starboard tension (kg)* b. Winch port tension (kg)* c. Winch middle tension (kg)* d. Winch starboard length (meter or feet)* e. Winch port length (meter or feet)* f. Winch middle length (meter or feet)* g. RPM starboard h. RPM port i. RPM middle j. Line speed starboard (meter or feet/min) k. Line speed port (meter or feet/min) l. Line speed middle (meter or feet/min) m. Towing time (meter or feet/min) 	<p>1.2.0.0</p>
<p>FEC - Furuno attitude message</p>	<p>\$PFEC, GPatt, aaa.a, bb.b, cc.c, *hh<CR><LF> 1. \$PFEC: Talker identifier + sentence formatter* 2. GPatt: Global positioning attitude, sentence formatter 3. aaa.a: Heading true* 4. bb.b: Pitch* 5. cc.c: Roll* 6. *hh: Checksum*</p>	<p>1.0.5.0</p>
<p>KW - Karmoy Winch</p>	<p>\$KWIN, a, b.b, T, c.c, M, d.d, rpm*hh<CR><LF> 1. \$KWIN: Talker identifier + sentence formatter* 2. a: Winch 0 = Stbd / Trawl 1 = Port Trawl Winch 3. b.b, T: Tensions (tons) 4. c.c, M: Length (meters) 5. d.d, rpm: Speed (rpm)</p>	<p>1.6.25.0</p>

Sentence	Format	First compliant version of Scalaz
<p>MA DD - Marelec winch length and tension</p>	<p># MA DD dd/mm/yy hh:mm:ss LB aaaam LS bbbbm LM ccccm TB ddddK TS eeeeK TM ffffK gg<CR><LF></p> <ol style="list-style-type: none"> 1. # MA DD: talker identifier* 2. dd/mm/yy: date 3. hh:mm:ss: time 4. LB aaaam: Shooted length portside in meters* 5. LS bbbbm: Shooted length starboard in meters* 6. LM ccccm: Shooted length center in meters* 7. TB ddddK: Tension of portside in kg* 8. TS eeeeK: Tension of starboard in kg* 9. TM ffffK: Tension of center in kg* 10. gg: system in 00 = MANUAL (stop), 10 = auto shooting, 20 = auto fishing, 30 = auto hauling, 40 = slow tension alarm without propeller reduction, 41 = slow tension alarm with propeller reduction, 50 = fast tension alarm without propeller reduction, 51 = fast tension alarm with propeller reduction* 	<p>1.2.0.0</p>
<p>MPT TXOR - Marport, transducer orientation</p>	<p>\$PMPT, TXOR, aa.a, bb.b, cc.c, d*hh</p> <ul style="list-style-type: none"> • \$PMPT: talker identifier + sentence formatter. • TXOR: Transducer Orientation • aa.a: pitch* • bb.b: roll* • cc.c: yaw* • s: V = valid / N = not valid* 	<p>2.0.0.0</p>
<p>NAV - Ifremer proprietary sentence</p>	<p>\$NANAV, 04/09/yy, hhhmmss.sss, NASYC, N, 48, 22.92315, W, 004, 28.90527, D, 00.0, WG84, 04/09/13, 13:05:37.000, COU, 346.08, -00.22, +00.13, +00.00, +00052.172, 000, 0000</p>	<p>1.0.0.0</p>
<p>IFM - Ifremer versatile sentence</p>	<p>\$PIFM, EU, MES, dd/mm/yy, hh:hh:ss.sss, TRFUN, ±a, bb, ccccc, dddd, e.e, f, ggggg, hhhh, i.i, j, <CR><LF></p> <ol style="list-style-type: none"> 1. \$PIFM: Talker identifier + sentence formatter* 2. OCGYR: pitch, roll, heading 3. TRFUN: winch lengths (starboard, port) and winch tensions (starboard, port) 	<p>1.0.0.0</p>

Sentence	Format	First compliant version of Scalaz
<p>SYN - Winch Syncro 2020, winch length and tension</p>	<p>\$WMSYN,aaa.a,m,bbb.b,m,ccc.c,m,ddd.d,m,ee.e,t,ff.f,t,gg.g,t,hh.h,t,0.5,x,0.7,x,1.6,s,2.0,s,0,0,1,0,0,45.5,c,33.0,p,32.8,p*31</p> <ol style="list-style-type: none"> 1. \$WMSYN: Talker identifier + sentence formatter* 2. aaa.a: winch starboard length in meters* 3. bbb.b: winch inner starboard length in meters* 4. ccc.c: winch inner port length in meters* 5. ddd.d: winch port length in meters* 6. ee.e: winch starboard tension in tons* 7. ff.f: winch inner starboard tension in tons* 8. gg.g: winch inner port tension in tons* 9. hh.h: winch port tension in tons* 10. Other strings are not used. 	<p>1.0.0.0</p>
	<p>\$WMSYN,aaa.a,c,bbb.b,c,ccc.c,c,dd.d,t,ee.e,t,ff.f,t*hh<CR><LF></p> <ol style="list-style-type: none"> 1. \$WMSYN: Talker identifier + sentence formatter* 2. aaa.a,l: Starboard wire length (m=meter)* 3. bbb.b,l: Mid wire length (m=meter)* 4. ccc.c,l: port wire length (m=meter)* 5. dd.d,t: Starboard wire tension, tons* 6. ee.e,t: Mid wire tension, tons* 7. ff.f,t: Port wire tension, tons* 	<p>1.6.19.0</p>
<p>TAWWL - RappHydema, PTS Pentagon warp length</p>	<p>@TAWWL,a,M,b,M,c,M*hh<CR><LF></p> <p>See below. M = meter</p>	<p>1.4.4.0</p>
	<p>@TAWWL,x,y,z*hh<CR><LF></p> <ol style="list-style-type: none"> 1. @TAWWL: Talker identifier + sentence formatter* 2. a: Starboard winch length* 3. b: Port winch length* 4. c: Middle winch length* 	<p>1.6.19.0</p>
<p>TAWWT - RappHydema, PTS Pentagon warp tension</p>	<p>@TAWWT,a.a,T,b.b,T,c.c,T*hh<CR><LF></p> <p>See below. T = tons</p>	<p>1.4.4.0</p>
	<p>@TAWWT,a.a,b.b,c.c*hh<CR><LF></p> <ol style="list-style-type: none"> 1. @TAWWT: Talker identifier + sentence formatter* 2. a.a: Starboard winch tension* 3. b.b: Port winch tension* 4. c.c: Middle winch tension* 	<p>1.6.19.0</p>

Sentence	Format	First compliant version of Scalaz
WCT - Warp length and tension (Silecmar)	<p>\$SIWCT, aaa,bbb,ccc,d.d,e.e,f.f*hh<CR><LF></p> <ol style="list-style-type: none"> 1. \$SIWCT: Talker identifier + sentence formatter* 2. aaa: Port winch cable, meters* 3. bbb: Starboard winch cable, meters* 4. ccc: Clump winch cable, meters* 5. d.d: Tension in the port winch, tons* 6. e.e: Tension in the starboard winch, tons* 7. f.f: Tension in the clump winch, tons* 8. *hh: Checksum* 	1.2.6.0
WIDA1 - Kongsberg warp length	<p>\$WIDA1, aa,bbbb,cc,0,dd,eeee,ff,1,g,h,i,2,k,l,m,3*hh<CR><LF></p> <ol style="list-style-type: none"> 1. \$WIDA1: Talker identifier + sentence formatter* 2. aa: port wire tension, tons* 3. bbbb: port wire out, meters* 4. cc: port wirespeed, m/min* 5. 0: port* 6. dd: starboard wire tension, tons* 7. eeee: starboard wire out, meters* 8. ff: starboard wirespeed, m/min* 9. 1: starboard* 10.g: port mid wire tension, tons* 11. h: port mid wire out, meters* 12.i: port mid wirespeed, m/min* 13.2: port mid* 14.k: stb mid wire tension, tons* 15.l: stb mid wire out, meters* 16.m: stb mid wirespeed, m/min* 17.3: starboard mid* 18.*hh: Checksum* 	2.2.2.0
WLP - Scantrol winch length (port)	<p>\$SCWLP, a.a,M,b.b,M*hh<CR><LF></p> <ol style="list-style-type: none"> 1. \$SCWLP: Talker identifier + sentence formatter* 2. a.a,M: paid out wire in meters* 3. b.b,M: wirespeed in meters/sec., positive when paying out wire 4. *hh: Checksum* 	1.0.6.0

Sentence	Format	First compliant version of Scalaz
WLS - Scantrol winch length (starboard)	<p>\$SCWLS, a . a , M , b . b , M*hh<CR><LF></p> <ol style="list-style-type: none"> 1. \$SCWLS: Talker identifier + sentence formatter* 2. a.a,M: paid out wire in meters* 3. b.b,M: wirespeed in meters/sec., positive when paying out wire 4. *hh: Checksum* 	1.0.6.0
WLC - Scantrol winch length (clump)	<p>\$SCWLC, a . a , M , b . b , M*hh<CR><LF></p> <ol style="list-style-type: none"> 1. \$SCWLC: Talker identifier + sentence formatter* 2. a.a,M: paid out wire in meters* 3. b.b,M: wirespeed in meters/sec., positive when paying out wire 4. *hh: Checksum* 	1.0.6.0
WLD - Scantrol winch length (triple trawl - port clump)	<p>\$SCWLD, a . a , T*hh<CR><LF></p> <ol style="list-style-type: none"> 1. \$SCWLD: Talker identifier + sentence formatter* 2. a.a,M: paid out wire in meters* 3. b.b,M: wirespeed in meters/sec., positive when paying out wire 4. *hh: Checksum* 	2.0.0.0
WLE - Scantrol winch length (quad trawl - center clump)	<p>\$SCWLE, a . a , T*hh<CR><LF></p> <ol style="list-style-type: none"> 1. \$SCWLE: Talker identifier + sentence formatter* 2. a.a,M: paid out wire in meters* 3. b.b,M: wirespeed in meters/sec., positive when paying out wire 4. *hh: Checksum* 	2.0.0.0
WTP - Scantrol winch tension (port)	<p>\$SCWTP, a . a , T*hh<CR><LF></p> <ol style="list-style-type: none"> 1. \$SCWTP: Talker identifier + sentence formatter* 2. a.a,T: tension in tons* 3. *hh: Checksum* 	1.0.6.0
WTS - Scantrol winch tension (starboard)	<p>\$SCWTS, a . a , T*hh<CR><LF></p> <ol style="list-style-type: none"> 1. \$SCWTS: Talker identifier + sentence formatter* 2. a.a,T: tension in tons* 3. *hh: Checksum* 	1.0.6.0
WTC - Scantrol winch tension (clump)	<p>\$SCWTC, a . a , T*hh<CR><LF></p> <ol style="list-style-type: none"> 1. \$SCWTC: Talker identifier + sentence formatter* 2. a.a,T: tension in tons* 3. *hh: Checksum* 	1.0.6.0

Sentence	Format	First compliant version of Scalaz
WTD - Scantrol winch tension (triple trawl - port clump)	$\$SCWTD, a . a , T * hh < CR > < LF >$ 1. \$SCWTD: Talker identifier + sentence formatter* 2. a.a,T: tension in tons* 3. *hh: Checksum*	2.0.0.0
WTE - Scantrol winch tension (quad trawl - center clump)	$\$SCWTD, a . a , T * hh < CR > < LF >$ 1. \$SCWTD: Talker identifier + sentence formatter* 2. a.a,T: tension in tons* 3. *hh: Checksum*	2.0.0.0

Pocket Drawings

Drawings to manufacture Spread Sensor pockets to be placed on trawl doors. Ask your local Marport Office for scaled templates.

Pocket Angle of Attack

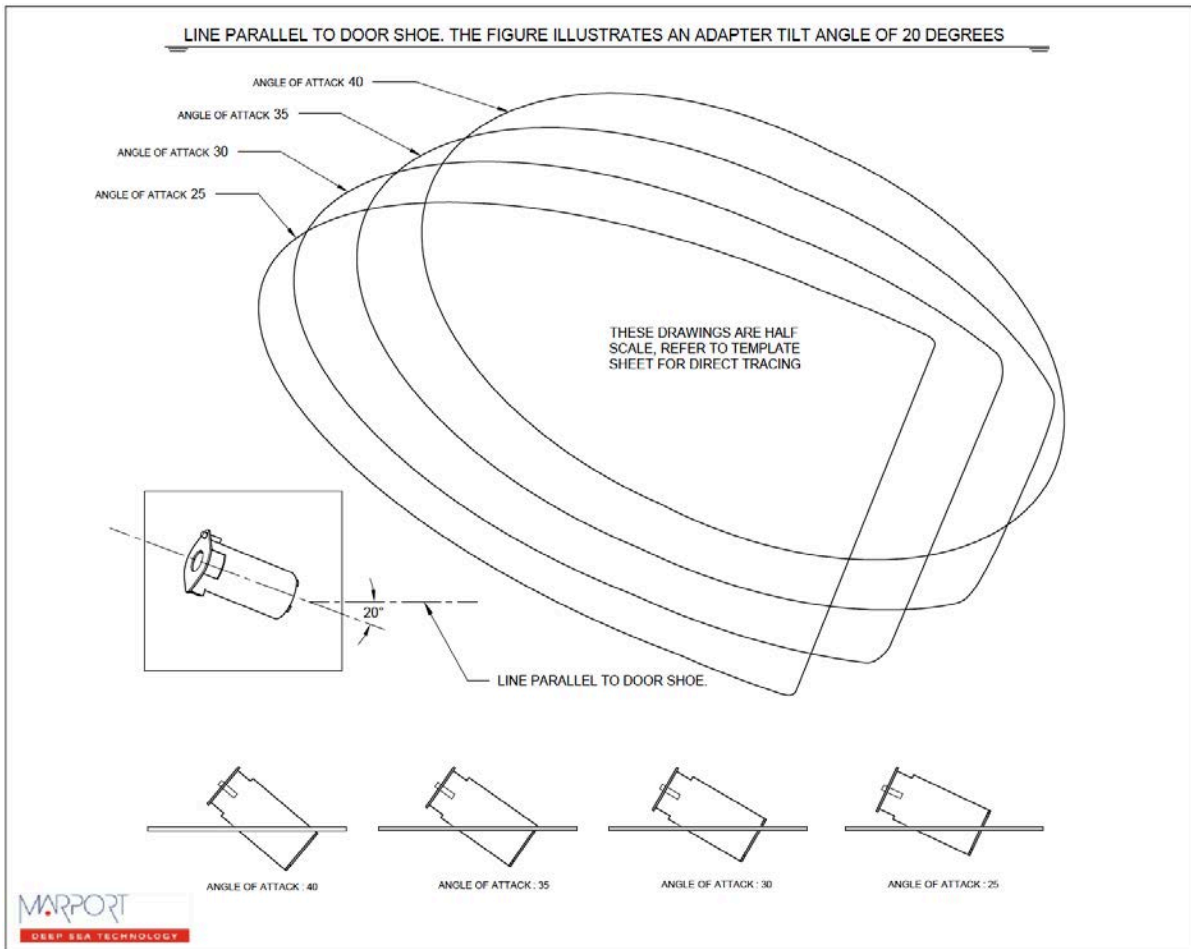

Pocket for XL Bottles

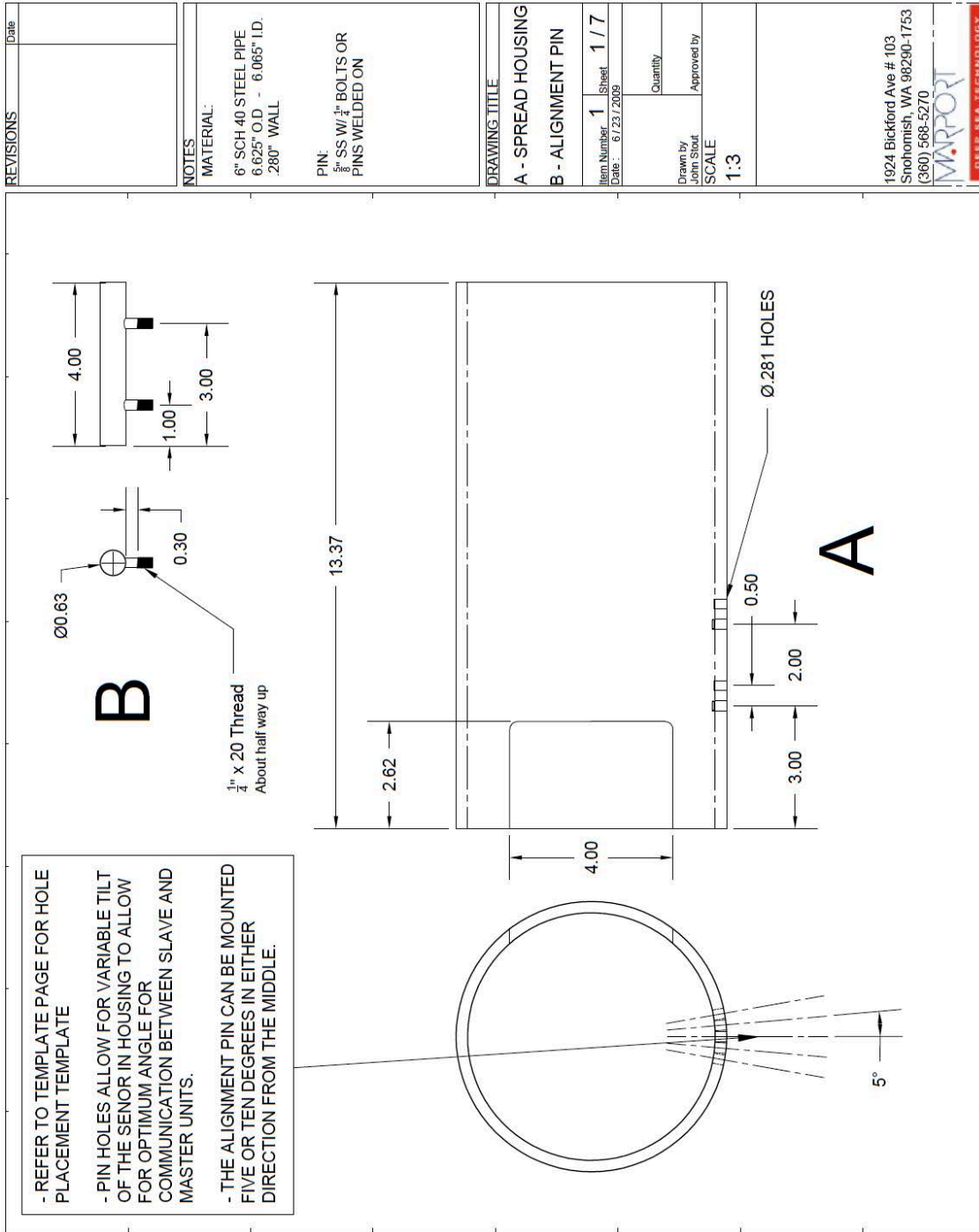

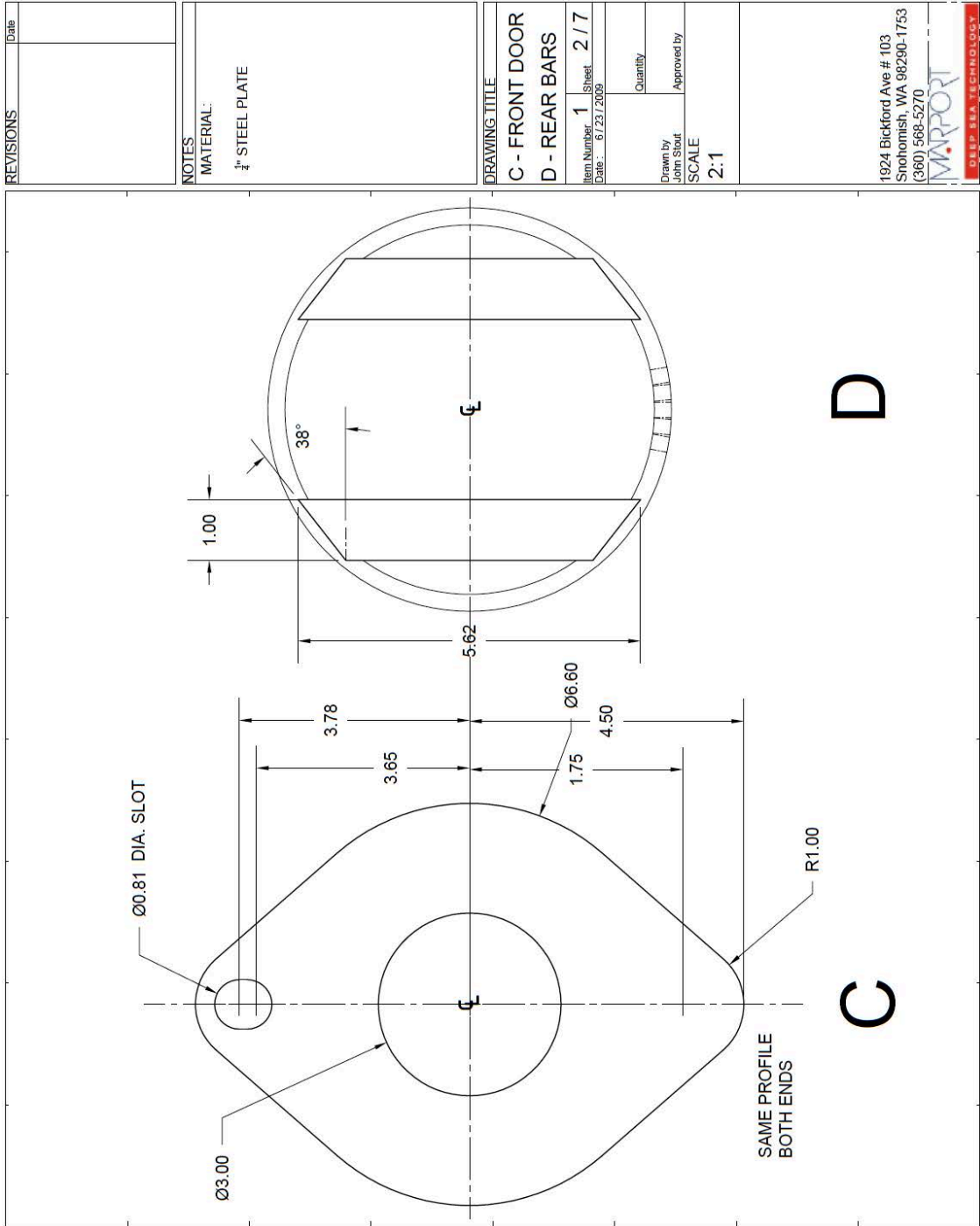

1924 Bickford Ave # 103
 Snohomish, WA 98290-1753
 (360) 568-5270

MARPORT
 DEEP SEA TECHNOLOGY

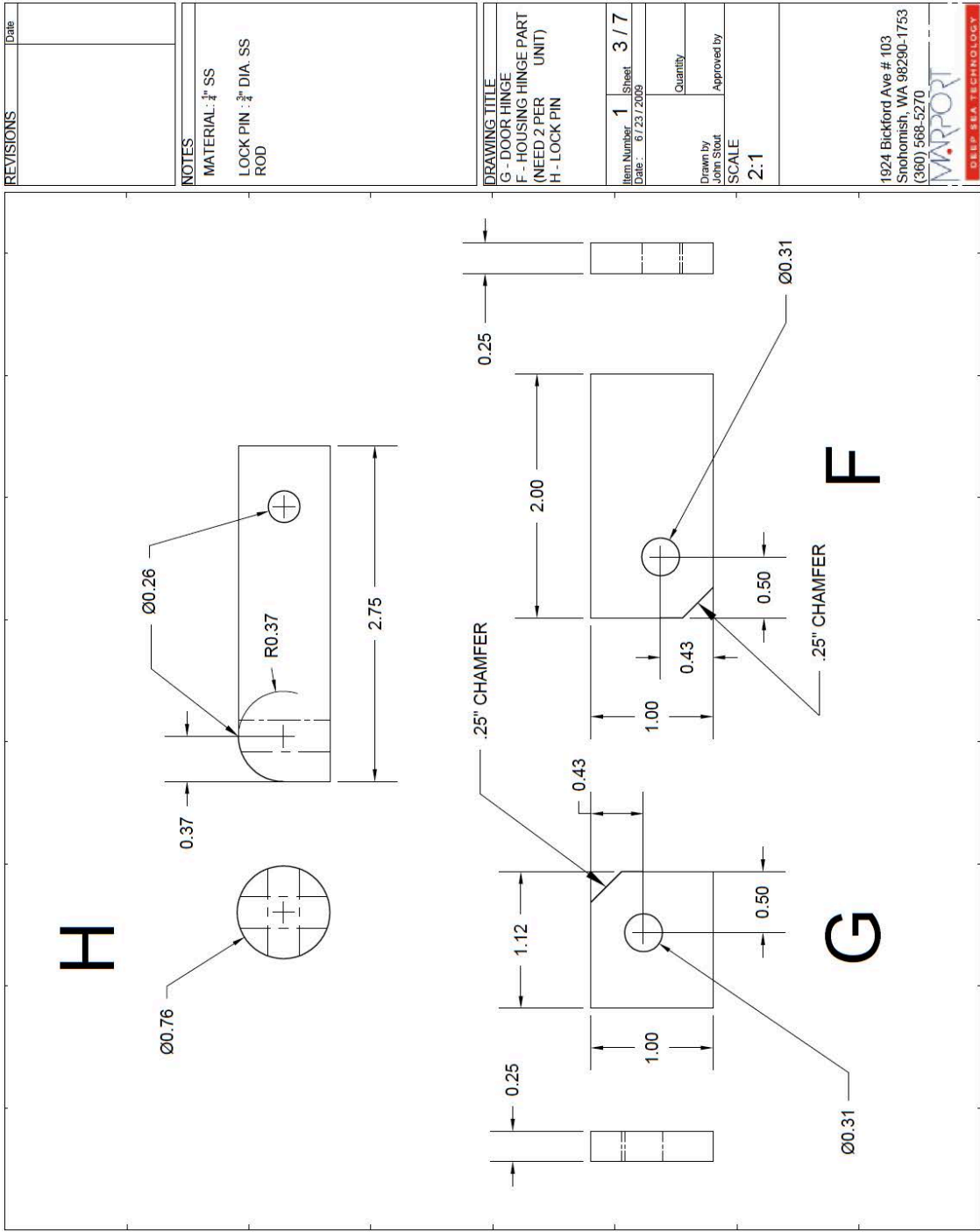

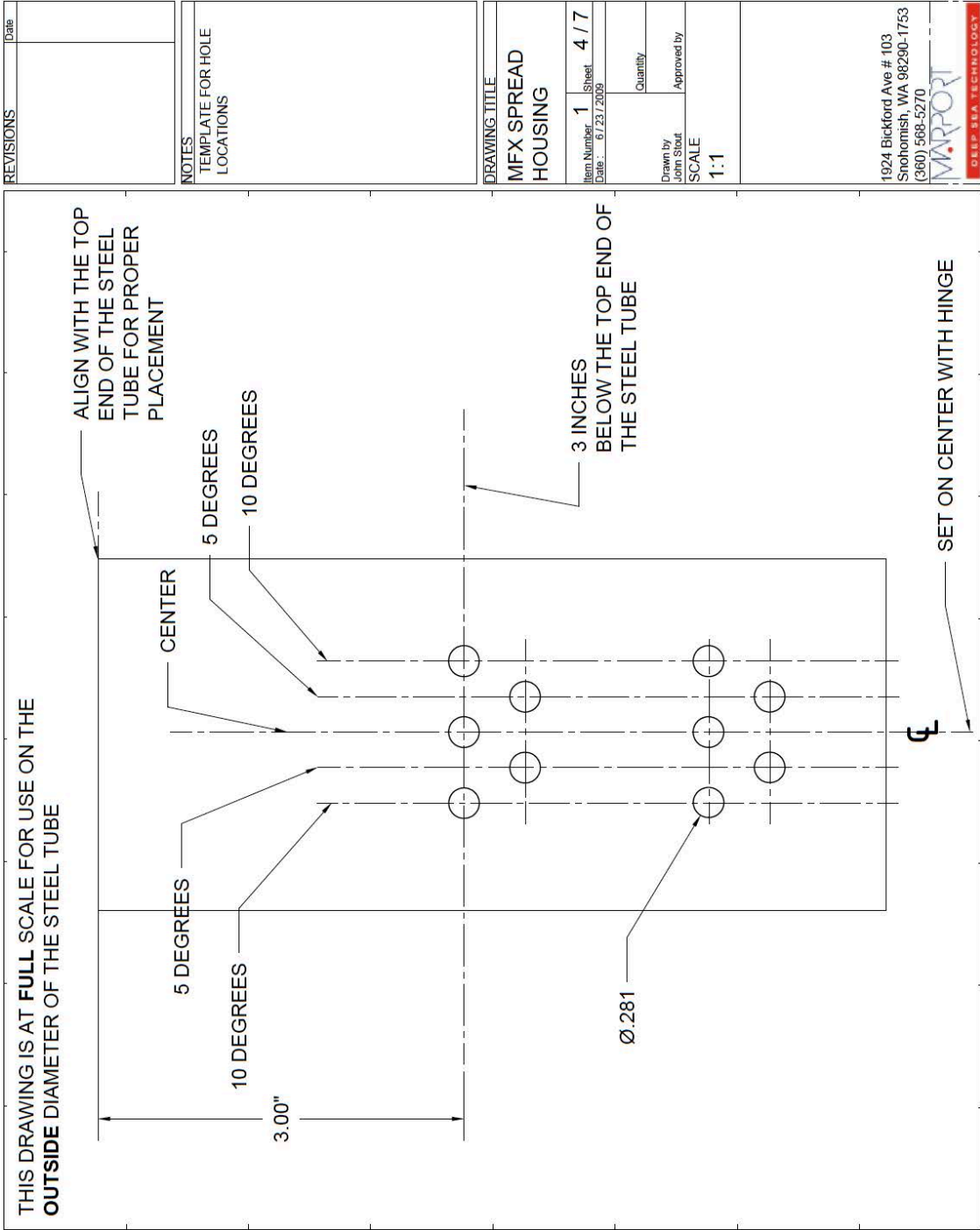

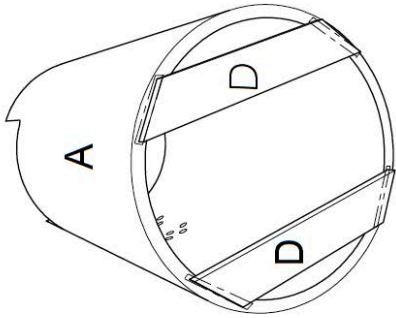

1. Weld both rear bars to main housing tube, ensuring they are parallel to front sensor opening.

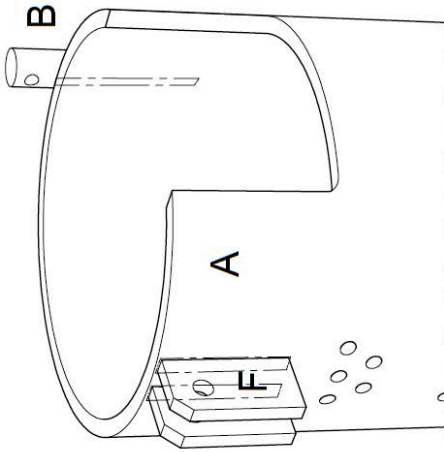

2. On the other end of the housing, weld the housing hinge bars to the top end, making sure both bars or the weld does not extend above the top of the tube.

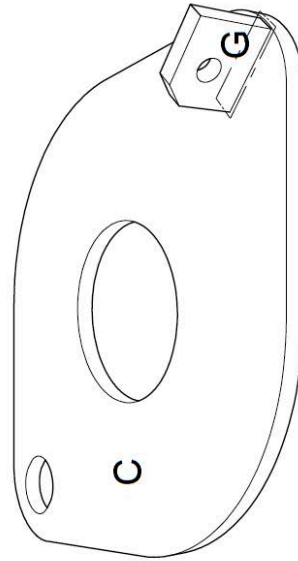

3. Next weld the door hinge onto the top end of the door piece, its distance from the edge is to be determined by the alignment of the opposite hole with the edge of the tube.

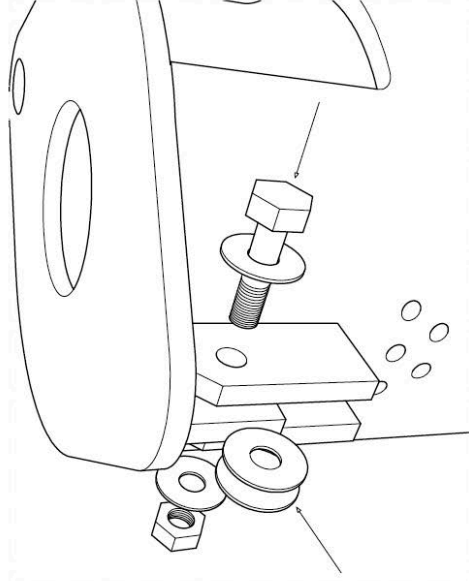

4. Place the $\frac{5}{16}$ x 1.5" bolt through the hinge with washers and $\frac{5}{16}$ nylock nut as shown

MFx SPREAD SENSOR HOUSING
Fabrication Instructions

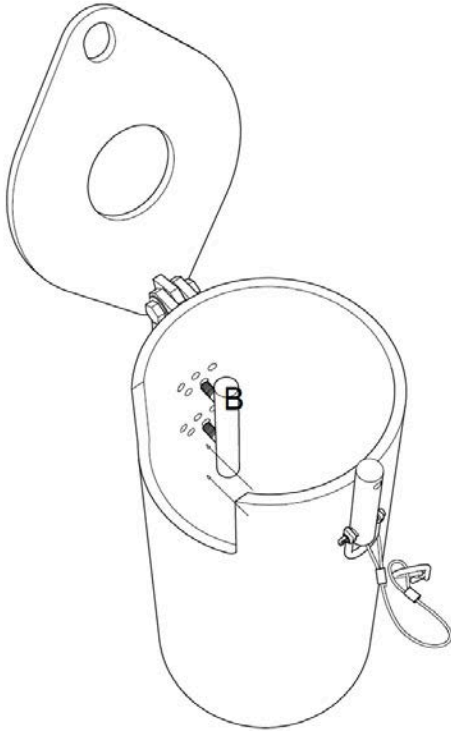

5. Now place the alignment bar at its center location. This can be adjusted for optimum performance of the sensor and once that position is found can be permanently welded into place.

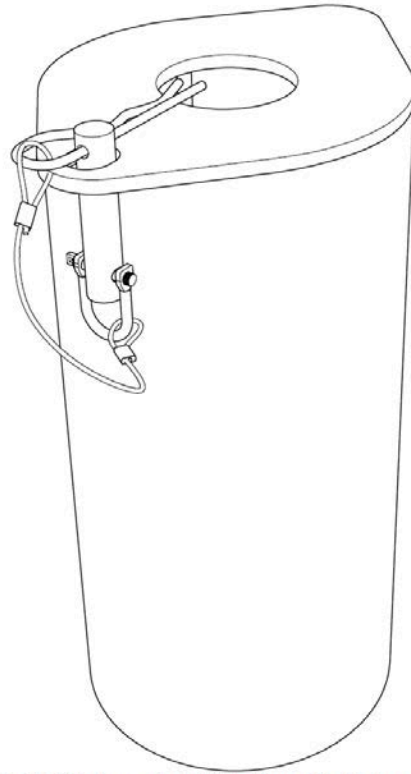

6. Now the final hardware, can be installed, including a safety cable shown on the next page.

MX SPREAD SENSOR HOUSING
Fabrication Instructions

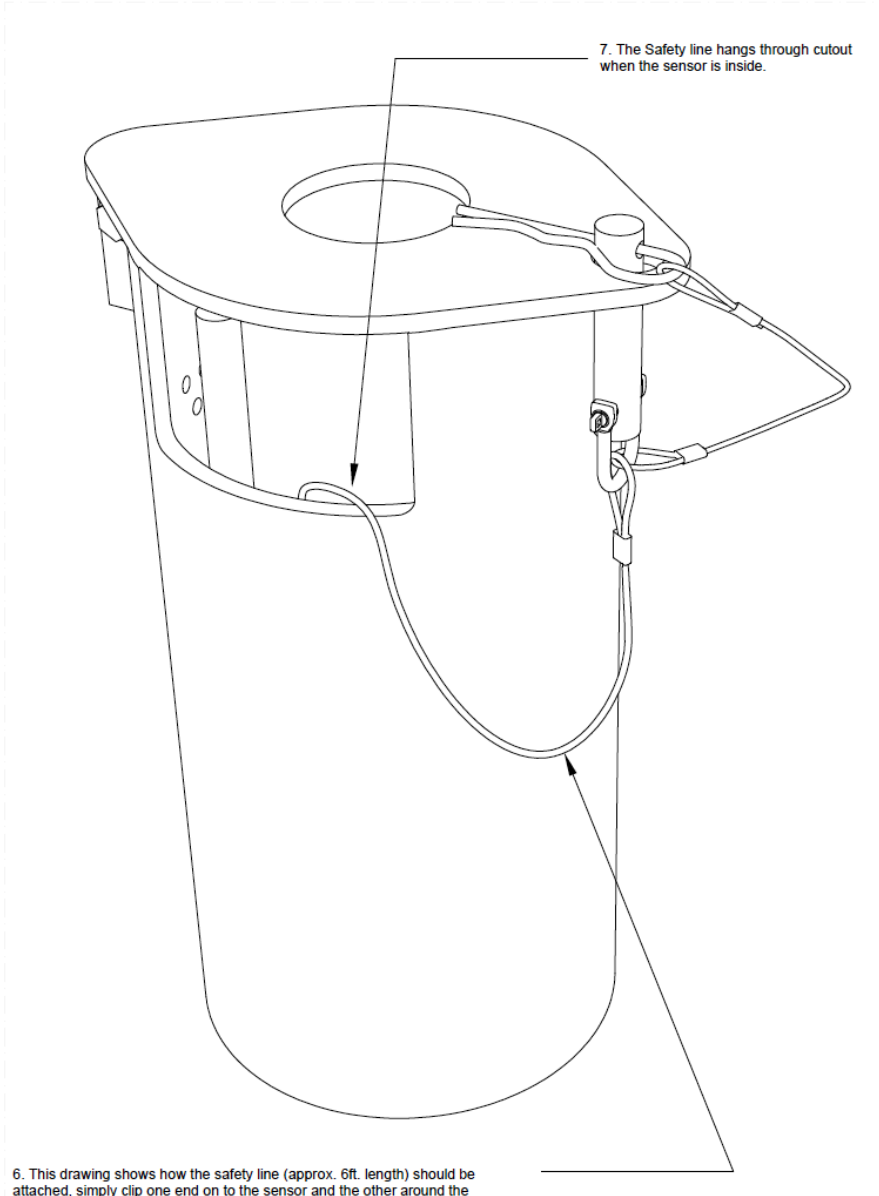

6. This drawing shows how the safety line (approx. 6ft. length) should be attached, simply clip one end on to the sensor and the other around the shackle as shown above.

MFX SPREAD SENSOR HOUSING
Fabrication Instructions

Pocket for Stubby Bottles

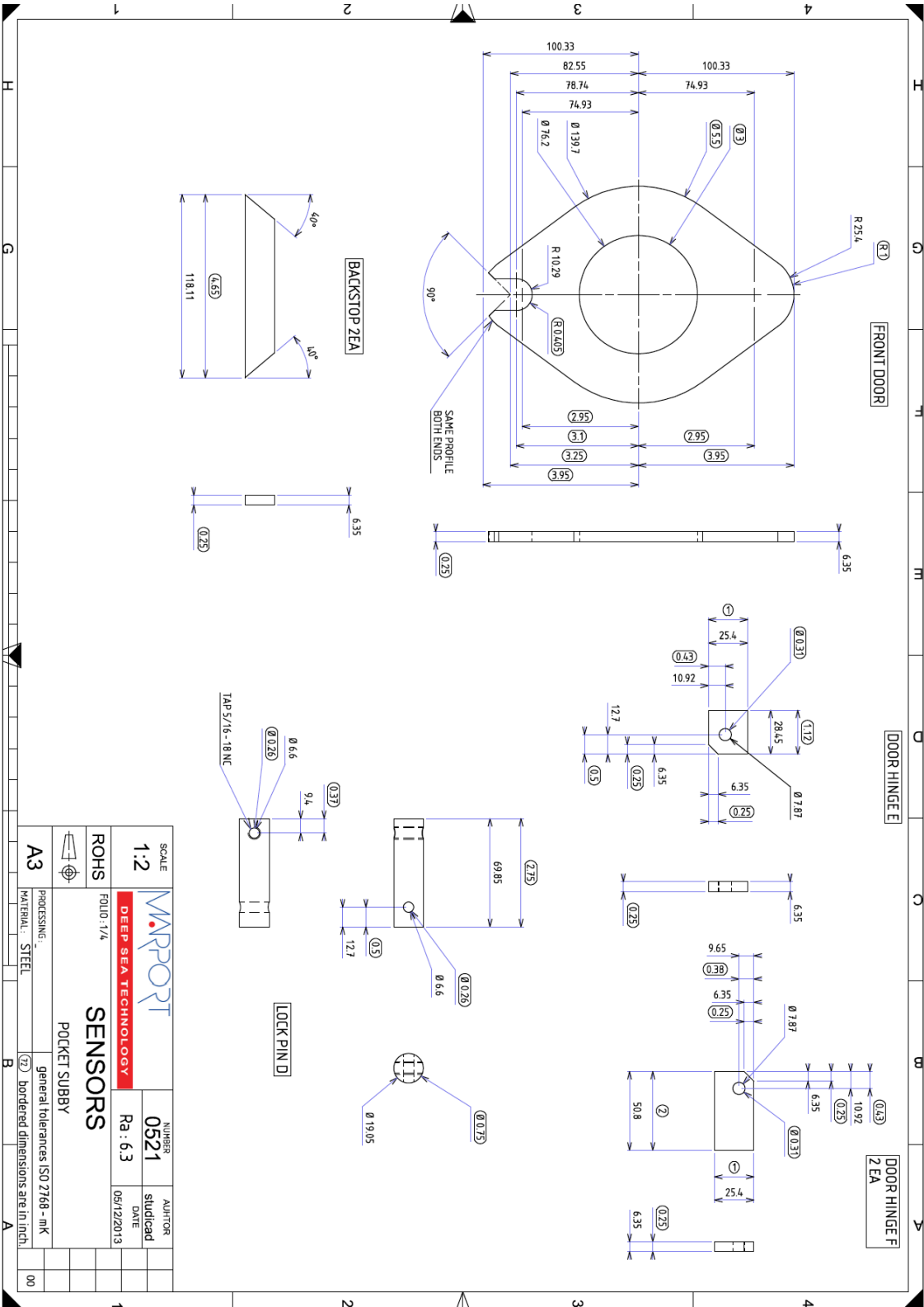

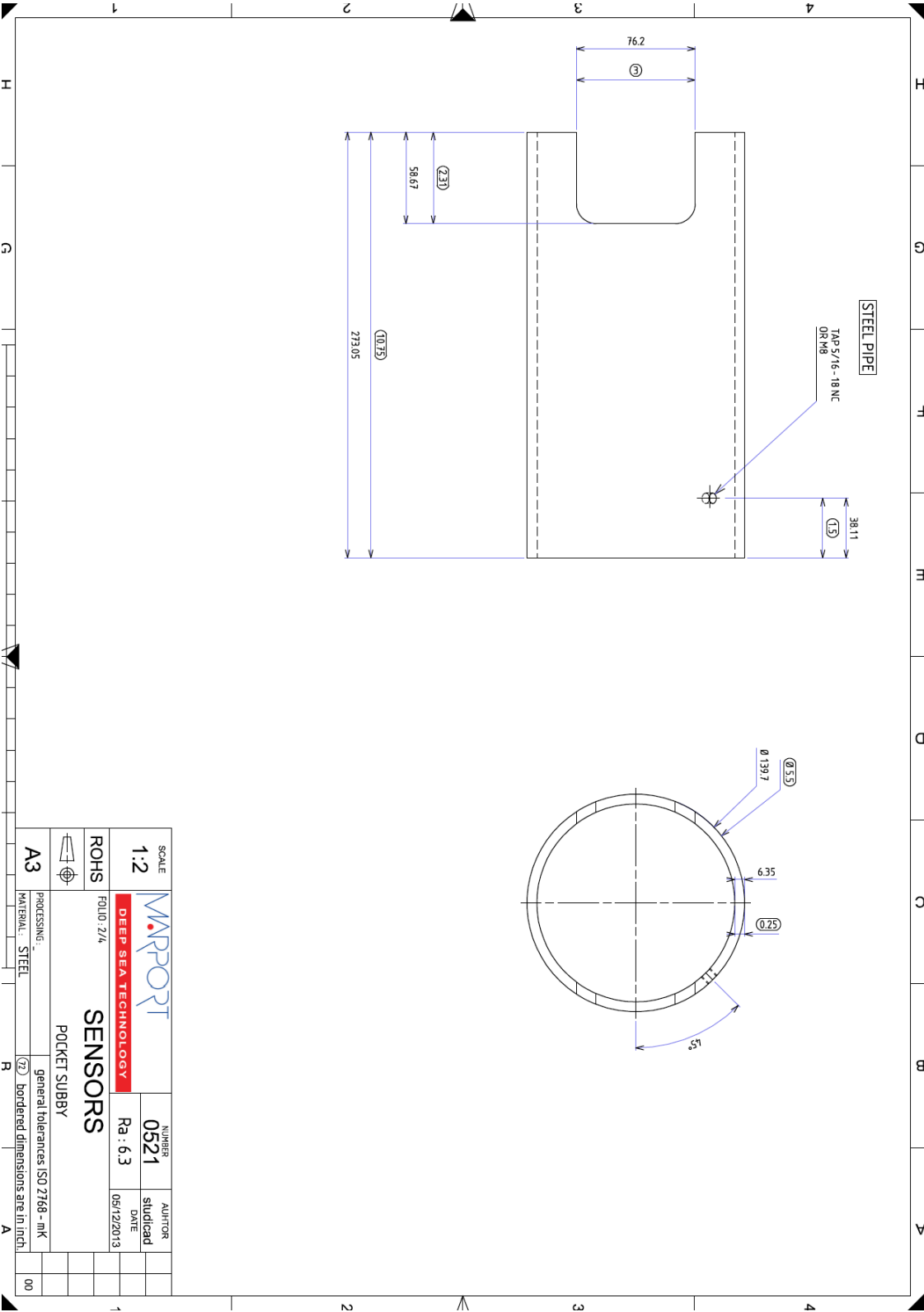

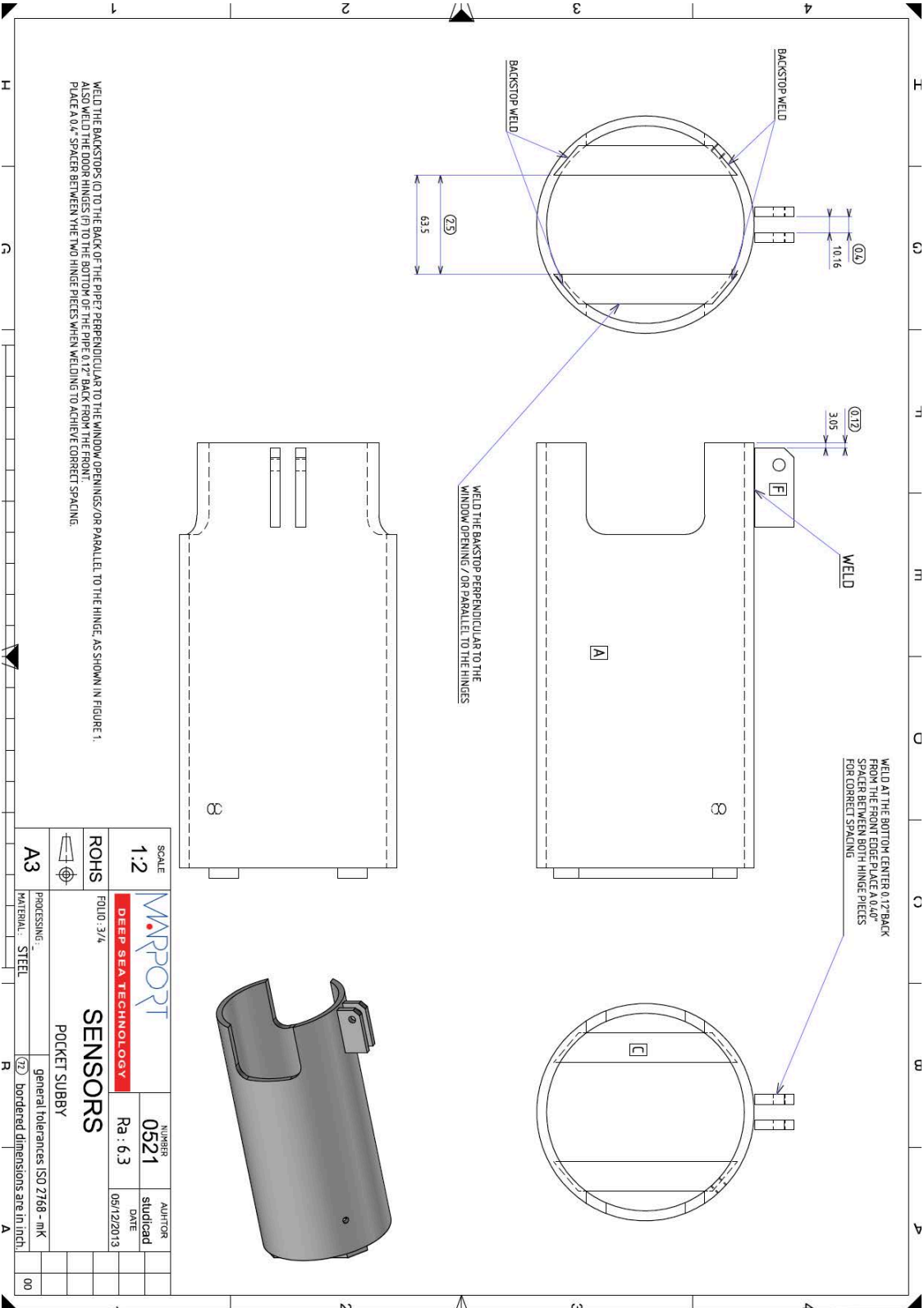

WELD THE BACKSTOPS (D) TO THE BACK OF THE PIPE PERPENDICULAR TO THE WINDOW OPENINGS / OR PARALLEL TO THE HINGE, AS SHOWN IN FIGURE 1.
ALSO WELD THE DOOR HINGES (F) TO THE BOTTOM OF THE PIPE 0.127" BACK FROM THE FRONT.
PLACE A 0.4" SPACER BETWEEN THE TWO HINGE PIECES WHEN WELDING TO ACHIEVE CORRECT SPACING.

SCALE	1:2	NUMBER	0521	AUTHOR	stuflead
ROHS	DEEP SEA TECHNOLOGY	DATE	Ra : 6.3	DATE	05/12/2013
PROCESSING	FOUO : 3/4	SENSORS POCKET SUBBY			
MATERIAL	STEEL				
general tolerances ISO 2768 - mK (Z) bordered dimensions are in inch.					
A3		00			

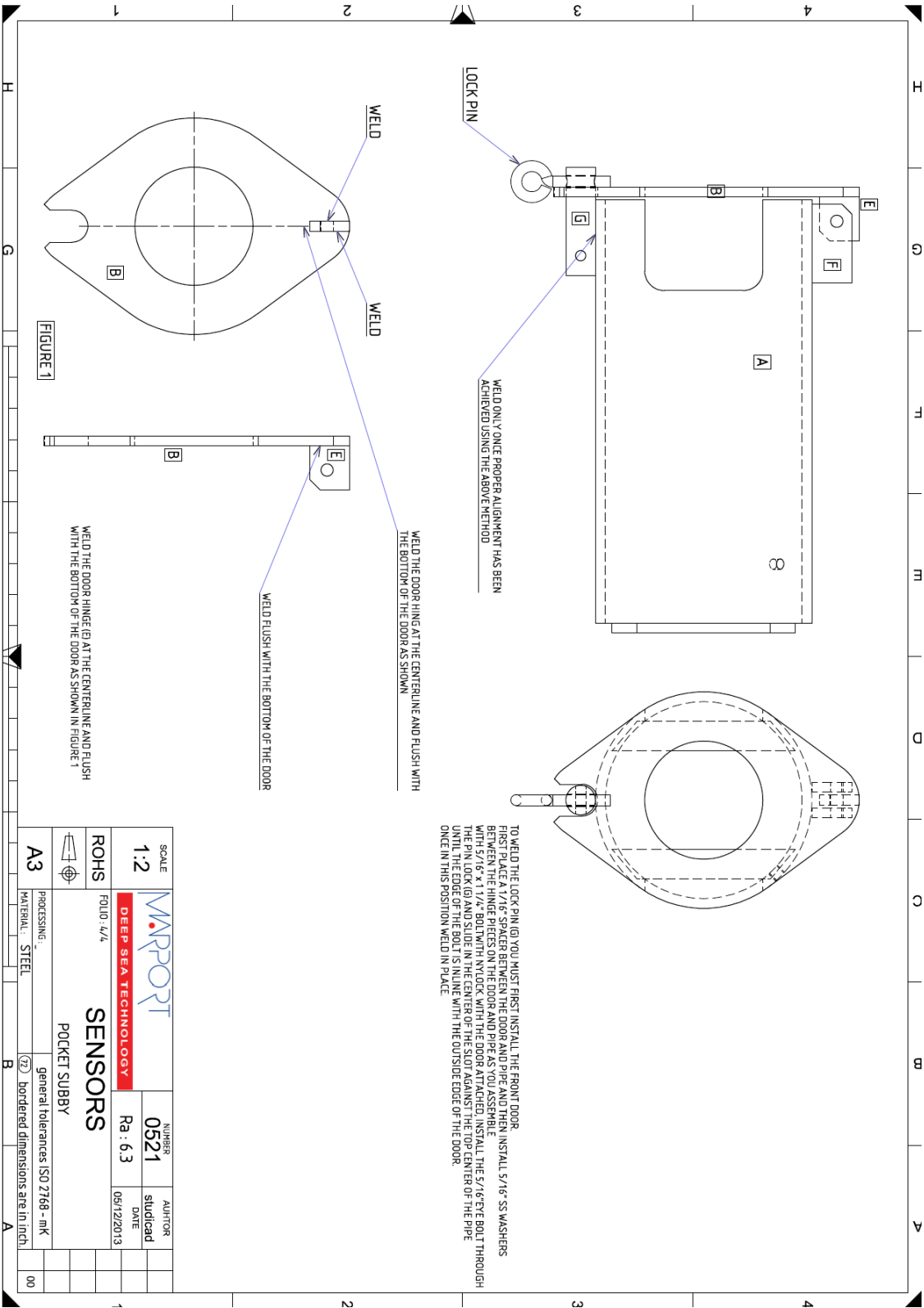

SCALE	1:2	NUMBER	0521	AUTHOR	studdad
ROHS	FOUO: 4/4	DEEP SEA TECHNOLOGY	Ra: 6.3	DATE	05/12/2013
PROCESSING	A3	SENATORS	POCKET SUBBY	general tolerances	ISO 2768 - mK
MATERIAL	STEEL	(Z)	bordered dimensions are in inch		

Pocket for Stubby Bottles with Slim Housing

THIRD ANGLE PROJECTION <input checked="" type="checkbox"/> FIRST ANGLE PROJECTION	REVISIONS REV. DESCRIPTION DATE X PRELIMINARY RELEASE ...	ECO NO. DATE CHECKED BY ...	DATE CHECKED BY ...
--	---	--------------------------------	------------------------

Ø X .00 .13 .133 FILLET WELD FULL LENGTH

PARTS LIST		DATE	DATE
ITEM NO.	DESCRIPTION	DATE	DATE
1	SMALL DOOR POCKET PIPE	04/25/17	
2	SMALL DOOR POCKET BAR	04/25/17	
3	3/8-16 NYLON LOCK NUT	04/25/17	
4	3/8-16 X 5.00" HEX HEAD BOLT	04/25/17	
5	10-32 X 3/8" CUP-POINT SET SCREW	04/25/17	

UNLESS OTHERWISE SPECIFIED DIMENSIONS ARE IN INCHES TOLERANCES ARE: FRACTIONS DECIMALS .0000 .0000 .0005 .0005 .0010 .0010 .0015 .0015 .0020 .0020 .0030 .0030 .0040 .0040 .0050 .0050 .0060 .0060 .0070 .0070 .0080 .0080 .0090 .0090 .0100 .0100 .0150 .0150 .0200 .0200 .0300 .0300 .0400 .0400 .0500 .0500 .0600 .0600 .0700 .0700 .0800 .0800 .0900 .0900 .1000 .1000 .1250 .1250 .1500 .1500 .1750 .1750 .2000 .2000 .2500 .2500 .3000 .3000 .3750 .3750 .4000 .4000 .5000 .5000 .6250 .6250 .7500 .7500 .8750 .8750 1.0000 1.0000 1.2500 1.2500 1.5000 1.5000 1.7500 1.7500 2.0000 2.0000 2.5000 2.5000 3.0000 3.0000 3.5000 3.5000 4.0000 4.0000 4.5000 4.5000 5.0000 5.0000 5.5000 5.5000 6.0000 6.0000 6.5000 6.5000 7.0000 7.0000 7.5000 7.5000 8.0000 8.0000 8.5000 8.5000 9.0000 9.0000 9.5000 9.5000 10.0000 10.0000	SIGNATURE: _____ DATE: _____ DRAWN: B. THOMPSON 04/25/17 CHECKED: E. REINHEIMER 04/25/17 TITLE: SMALL DOOR POCKET MARRPORT AIRMAR TECHNOLOGY CORPORATION 10000 W. BASSWOOD AVE. #113 MURFREESBORO, TN 37132-1113 TEL: 662-375-3200 FAX: 662-375-3024
---	--

SEE PARTS LIST MATERIAL: _____ FINISH: _____ SCALE: 3/4" = 1" SHEET 1 OF 1	REV. A DO NOT SCALE DRAWING
--	--------------------------------

THIS DOCUMENT AND THE DATA DISCLOSED HEREIN OR HEREWITH IS NOT TO BE REPRODUCED, USED, OR DISCLOSED IN WHOLE OR IN PART TO ANYONE WITHOUT THE PERMISSION OF AIRMAR.

General Installation Instructions and Drawings

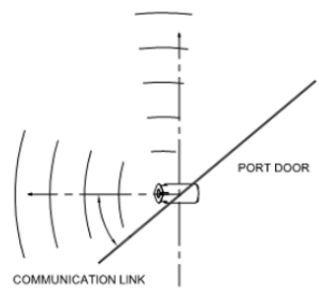
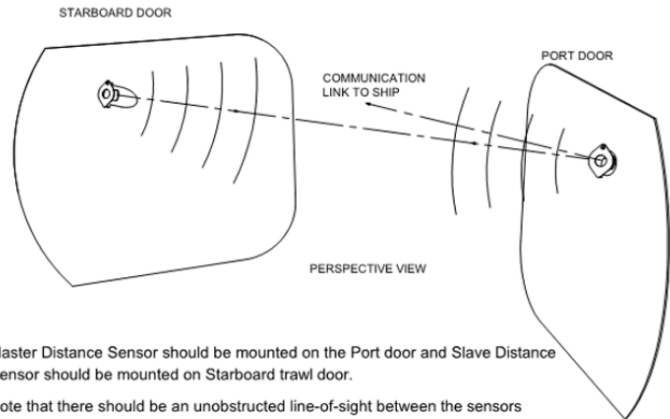
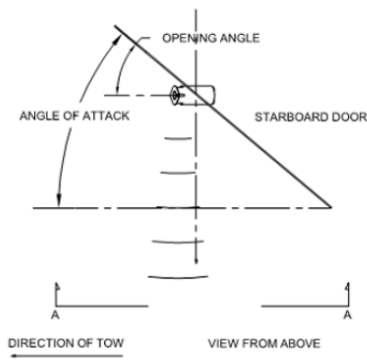

- Master Distance Sensor should be mounted on the Port door and Slave Distance Sensor should be mounted on Starboard trawl door.
- Note that there should be an unobstructed line-of-sight between the sensors (side transducer) when properly mounted (communication link between sensors). There should also be an unobstructed line of sight for communications between the Master Distance Sensor and the vessel's receiving hydrophone.
- For bottom trawling applications, the sensor adapter pocket should be mounted in the upper part of the trawl door but in a place with the least influence in the center of gravity of the door. Consult door manufacturer for details.
- Tilt (elevation angle) should be adjusted in accordance to best performance based on operational depth and length of the trawl gear.
- The door pocket adaptor is designed to compensate for the angle of attack of the trawl door, under normal operational conditions and based on a standard recommendation of 35°.
- Refer to cut-out templates for higher or lower angles. Consult door manufacturer for optional mounting angles.

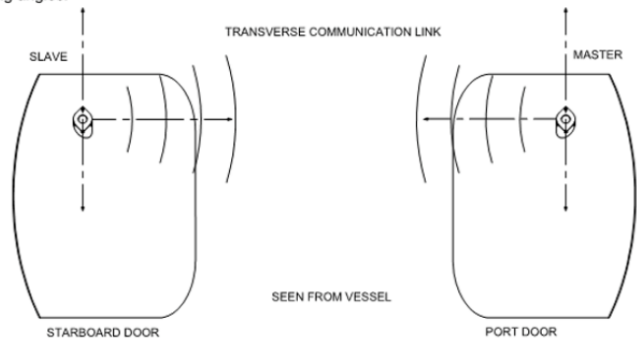
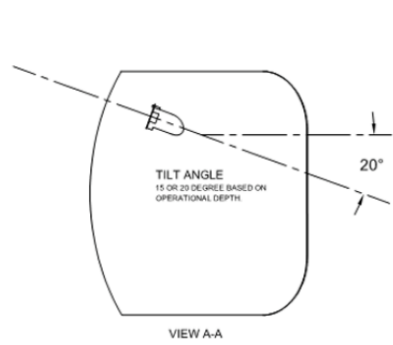

Index

Numerics

- 3D
 - Clump 41
 - Doors 41, 44
 - Trawl 48

A

- Angle of attack 60

B

- Battery
 - Lifetime 19
- Bearing 54
- Boat code 74

C

- Calibration
 - Pitch and roll 23
- Channel code 74
- Charger
 - Connecting 66
- Chart view
 - Display 54
 - Wrong 70
- Cleaning 67
- Communication
 - Between trawls 9
 - Protocol 9
- Compatibility 9
- Configuration Cable
 - Troubleshooting 69

D

- Dimensions 14
- Dock 66
- Door spread
 - Settings 19

E

- Elevation angle 60

F

- Frequency plan 74

G

- GPS
 - Adding 36
 - NMEA sentences 79

H

- Heading
 - Adding 36
 - NMEA sentences 79

I

- Installation overview 9

L

- Lost distance 72

M

- Maintenance
 - Schedule 68
- Measures 26
- Mosa2
 - Cannot start 69
 - Error message 69
 - Opening 17
- Mosa2 configuration
 - Change 27
 - Delete 27
 - Export 29
 - Import 30
 - Save 27
- Motion 23
- Multitrawl view
 - Display options 49
 - Displaying 48
 - Examples 52
 - Trawl setup 49

N

- NMEA inputs
 - Adding 36
 - Compatibility 79

O

- Offsets
 - Depth 25
 - Pitch and roll 23
 - Temperature 25
- Opening angle 60

P

- Pitch and roll
 - Calibration 23
 - Incorrect 72
- Pocket
 - Drawings 87
 - Elevation angle 88
 - Installation 63
 - Spread Sensor 89
 - Stubby bottle 96
 - Stubby bottle with Slim Housing 100
 - XL bottle 89
- Positioning
 - About 11
 - Calculations 34
 - Chirp settings 23
 - Data display 54
 - Receiver settings 33
 - Trawl settings 35

R

- Receiver
 - Adding to 31
 - Compatibility 31
 - Compatible firmware 31
 - Sensor settings 31

S

- Spread distances
 - Lost 72

- Stubby bottle
 - Components 15
 - End cap 15
 - Housing 15

T

- Technical specifications 14
- Telegrams
 - List 21
 - Order 21
- Tilt angle 60
- Trawl
 - 3D 41
 - Modeling 35
 - Node 20
 - Settings 35
 - Setup 57
- Trawl doors
 - View 44

U

- Uplink
 - Frequency 21
 - Power 21

W

- Warp length
 - Adding 36
 - NMEA sentences 79
 - Scantrol 39

X

- XL bottle
 - Components 15
 - End cap 15
 - Housing 15